

Reference Manual



POWER FACTOR CONTROLLER

CX eco



Table of content

1. Revision history	4
2. Safety notes	5
3. Connection	6
3.1 Connection diagram	6
3.2 Options	6
3.3 Terminals	7
3.4 Installation	8
4. Commissioning	9
5. Display indications	10
5.1 General	10
5.2 Alarm messages	11
5.3 Error and status messages	12
6. Operation of the controller	13
6.1 Operating concept	13
6.2 Entering values	14
7. Menu guide	15
7.1 Measurement menu	15
7.2 INFO – Stage database	18
7.3 MANUAL – Switching stage outputs manually	19
7.4 SETUP – Controller setup	20
7.5 ALARM – Alarm memory	22
8. Settings	24
8.1 Overview	24
8.2 100 Quick Start	25
8.3 200 Measurement	27
8.4 300 Control	29
8.5 400 Stage database	32
8.6 500 Alarm	34
8.7 600 Reset menu	38
8.8 700 ---	39
8.9 800 System	39
9. Control algorithm	40
9.1 BEST-FIT (AUTO)	40
10. Automatic initialization	41
10.1 Run Ai	41
10.2 Abort Ai	41
11. Stage features	42
11.1 Automatic stage size detection	42
11.2 Manual stage size adjustment	42
11.3 Adding stages	42
11.4 Detect power losses	43
11.5 Detection and reset of faulty stages	43
11.6 Automatic switching distribution	44
11.7 Additional 7 th or 13 th stage output	44
11.8 Over temperature protection	44
11.9 THD-U / THD-I protection	45
12. Fan control	46
13. Transformer compensation	47



13.1 Reactive power offset	47
13.2 Medium-voltage current measurement	47
14. Frequently asked questions	48
14.1 General.....	48
14.2 Alarms	50
14.3 Stages.....	51
14.4 Fan.....	52
15. Factory settings	53
16. Specifications.....	56
17. Appendix.....	58
17.1 Phase-correction-angle: Connection dependent.....	58
17.2 Phase-correction-angle: Twisted connection	58
17.3 Phase-correction-angle: Medium-voltage current measurement.....	58



1. Revision history

Date	Name	Revision	Comment
26.03.19	SMi	1.0	First edition



2. Safety notes

The following safety notes and instruction have to be read attentively and carefully. Familiarize yourself with the device before installation, commissioning and operation. The following symbols are found in the instruction manual and on the back of the device to indicate hazards and problems or to give specific instructions.

DANGER

DANGER indicates a dangerous situation which cause death or severe injuries if it is not avoided.

WARNING

WARNING indicates a dangerous situation which may cause death or severe injuries if it is not avoided.

CAUTION

CAUTION indicates circumstances which may damage or destroy the device in case of non-observance, but do not cause injuries.

NOTE boxes provide information about the correct operation of the devices. Special features are highlighted and discussed in more detail.



3. Connection

3.1 Connection diagram

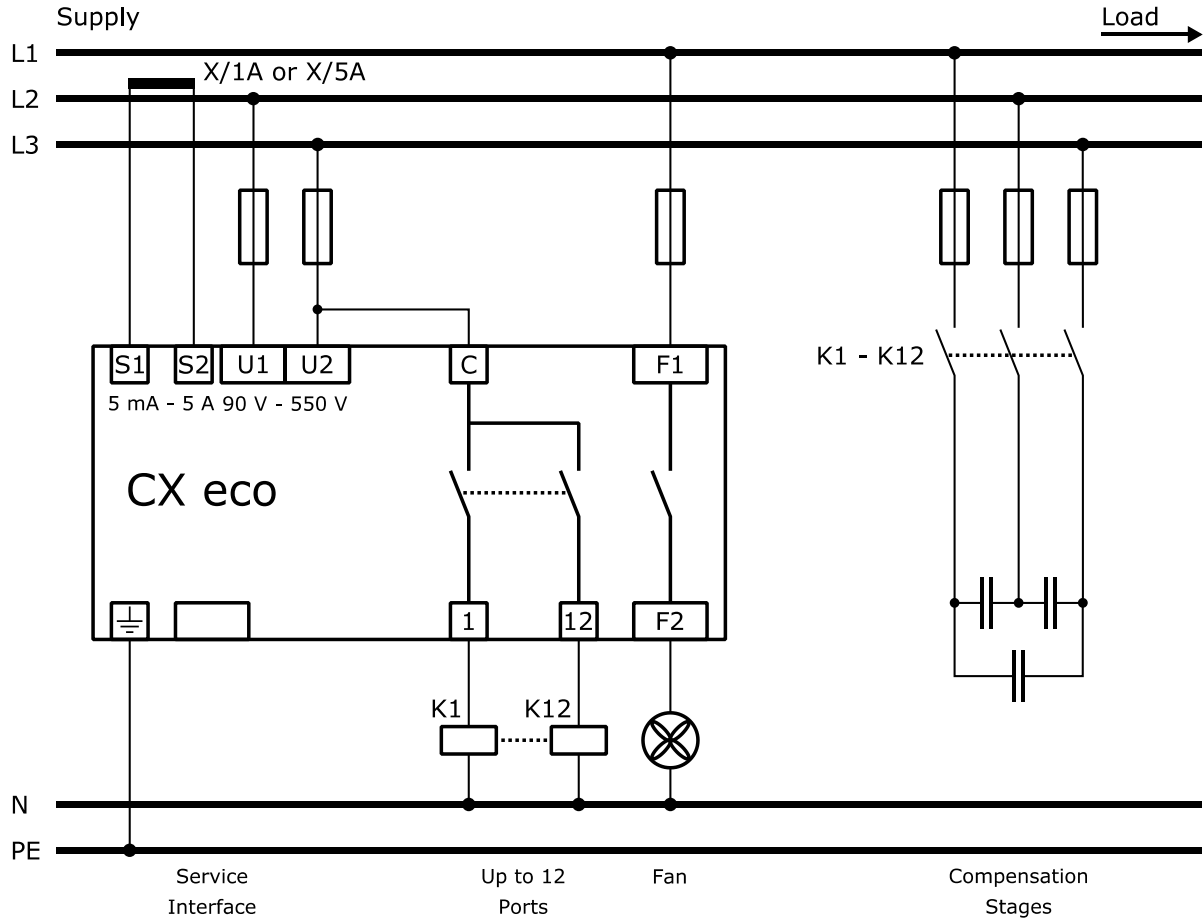

NOTE: The CX eco is designed to control **capacitive or inductive** stages. Operating both stage types simultaneously is not possible.

NOTE: The relay stage outputs are **not** suitable for controlling thyristor switches.

3.2 Options

Designation	Option
CX eco -06R	6 Stage outputs, Type: Relays
-12R	12 Stage outputs, Type: Relays



3.3 Terminals

Voltage measurement / supply

Combined voltage measurement and supply

Terminal: U1 / U2

Voltage transformer ratio: 1.0 – 350.0

Current measurement

Current measurement

Terminal: S1 (K) / S2 (L)

Current transformer ratio: 1 – 9600

x/1 and x/5 transformers can be used

Stage outputs

Type: Relay, normally-open, potential-free

Supply terminal: C

Output terminal: 1 – 6 or 1 – 12

Fan output

Closes if the temperature threshold TEMP1 is exceeded or can be used as additional 7th or 13th stage output

Type: Relay, normally-open, potential-free

Terminal: F1 / F2

Service-Interface

For service purpose only



3.4 Installation

Danger

Installation, commissioning and maintenance may only be carried out by a qualified electrician. An electrician is a person who has the ability, experience and knowledge necessary for the construction, installation and operation of electrical devices and systems and who has been instructed in the identification and avoidance of possible hazards.

During installation, the relevant regulations for the installation of switchgear and for accident prevention must be observed. Devices with damaged or open housings or terminals must not be operated on the power grid and must be disconnected immediately.

The current transformer must be short-circuited before disconnecting the current measuring path from the device or the current transformer. Non-compliance can lead to a life-threatening voltage at the terminals or the current transformer. The transformer is destroyed by a persistently high voltage.

- 1) Before installation, the connection specifications of the CX eco must be compared with the data of the power grid.
- 2) Disconnect the power supply and secured the working area against unauthorized and unintentional reconnection. Check if the disconnected area is voltage-free using a standardized measuring instrument. The voltage-free system must be earthed and short-circuited. Neighboring live parts must be covered and/or bypassed.
- 3) The current transformer must be short-circuited. A current transformer which has not been short-circuited generates a life-threatening voltage. This can lead to a destruction of the current transformer.
- 4) Insert the CX eco into the panel cut-out and fix it with the two fixing clamps.
- 5) Connect the grounding cable to the intended terminal on the backside of the device.
- 6) All cables must be connected as it is depicted in Chapter 3.1. The terminal K of the current transformer must be connected to terminal S1 and the terminal L to terminal S2.
- 7) Remove the short-circuit bridge at the current transformer.
- 8) The voltage can now be switched on.
- 9) If the device is connected correctly, the display will light up for one second and all symbols will be displayed during a display test.
- 10) Now, the current transformer factor must be entered.
- 11) If necessary, the nominal voltage and the voltage transformer factor must be adjusted.
- 12) The Automatic initialization (Ai) must be started (SETUP/100/Ai or SETUP/207 = **YES**).
- 13) After a successful Automatic initialization, the **AUTO** symbol appears in the displayed. When the discharge time has elapsed, the automatic control starts.



4. Commissioning

The factory settings of the CX eco allow a simple commissioning within 400 V power grids. Only the current transformer factor must be entered to obtain correct measurement values and to ensure the correct detection of the stage sizes (SETUP/Ct). The measured current and power values are only displayed if a current transformer factor has been set.

If the measured voltage and current are within the tolerance, the display shows **AUTO** and the measured $\cos \varphi$. Usually, the $\cos \varphi$ is inductive. This is indicated in the display by a small **i** in the end of the first line. From this moment, the discharge time of the stages runs. After the discharge time has elapsed, the CX eco starts the automatic control. While switching stages, the stage sizes are automatically detected. Outputs which are not used, are automatically set to the stage type **FOFF** if three successive switching operations have been unsuccessfully. From now on, the affected outputs will be ignored by the controller.

If the phase angle between the measured voltage and current is not 0° (voltage measurement L-N) or 90° (voltage measurement L-L), the Automatic initialization must be started (SETUP/100/Ai or SETUP/207 = **YES**) or the phase-correction-angle must be entered manually (SETUP/206). Entering the phase-correction-angle manually, please refer to Chapter 17.

NOTE: The Automatic initialization determines the phase angle between voltage and current and detects which stage outputs are used. However, the automatic detection of the stage size is performed during the usual control.

NOTE: The Automatic initialization is only possible in conjunction with capacitive stages. The use of inductive stages requires a manual input of the phase-correction-angle (SETUP/206). Moreover, the stage sizes must be entered manually (SETUP/402).



5. Display indications

5.1 General



The currently selected main menu appears on the right side of the display.

AUTO or no display Measurement menu

INFO Stage database

AUTO Automatic control is active (for information purpose only, no menu-function)

MANUAL Switching stage outputs manually

SETUP Controller setup

ALARM Alarm memory

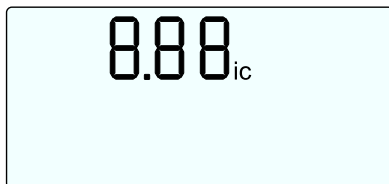

The first line of the main window shows the current $\cos \varphi$. A small **i** or **c** indicates whether the $\cos \varphi$ is **inductive** or **capacitive**. In the respective submenus, this line shows the name of the current item.

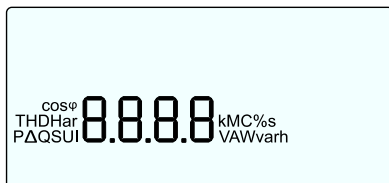

The second line of the display shows the set and measured values (center) with the corresponding symbol (left) and the units (right). Messages are also displayed in this line.

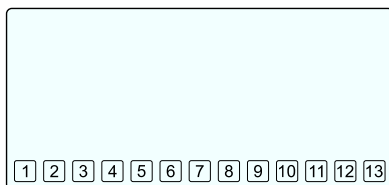

The stage outputs can be found in the lower part of the display. Displayed stage numbers represent an activated stage. If a stage has been detected as faulty, the corresponding stage symbol flashes.

Within the stage menu or the stage database, the currently selected stage is indicated by a flashing symbol.

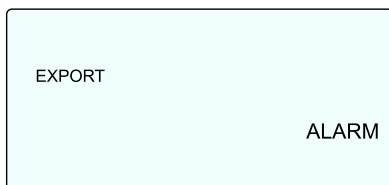

EXPORT Reverse current flow. Active power is supplied to the power grid.

ALARM This symbol flashes if an alarm is active.



5.2 Alarm messages

In the event of an alarm, the **ALARM** symbol and an alarm message flash on the display. If several alarms are active, alarm messages are cycled through after three flashes.

U	ALARM	The measured voltage is out of the set tolerance.
I Lo	ALARM	The measured current is smaller than 5 mA.
I hi	ALARM	The measured current is higher than 6 A.
PFC	ALARM	The controller cannot reach the set compensation target.
HArU	ALARM	The set THD-voltage threshold has been exceeded.
HArI	ALARM	The set THD-current threshold has been exceeded.
StEP FltY	ALARM	At least one stage is faulty. The stage symbol of the faulty stage and the error code flash alternately.
SPL Nr	ALARM	The reactive power of at least one stage has fallen below 75 % of the initial power value. The error code and stage number flash alternately. Only the smallest stage number of the affected stages is shown.
thi	ALARM	The second temperature threshold has been exceeded.
OPh	ALARM	The set operating-hours threshold of the controller has been exceeded.
OPC Nr	ALARM	The maximum switching-cycles threshold of at least one stage has been exceeded. The error code and the stage number flash alternately. Only the smallest stage number of the affected stages is shown.
OPh Nr	ALARM	The set operating-hours threshold of at least one stage has been exceeded. The error code and the stage number flash alternately. Only the smallest stage number of the affected stages is shown.
SYS 004F	ALARM	A system alarm has been triggered. The display shows the message SYS alternating with a four-digit error code. The device is defective and must be returned to BELUK GmbH.



NOTE: Alarm messages are shown in the main window only. The main menus **INFO**, **MANUAL**, **SETUP** or **ALARM** must not be selected.

NOTE: Depending on the configuration (SETUP/501), alarm messages which are no longer pending are automatically reset after 15 s or must be reset manually by pushing the ◀ (ESC) key (3 s).

5.3 Error and status messages

Error messages:

Ai / Abrt	The Automatic initialization has been aborted due to an error. The control is switched off.
------------------	--

NOTE: An error message can be reset by pushing the ◀ (ESC) key (3 s).

Status-messages:

FAn	The temperature threshold TEMP1 has been exceeded and the fan relay is switched on.
PFC / OFF	The control is switched off.
PFC / Hold	The control is suspended.

NOTE: Status messages cannot be reset by pushing the ◀ (ESC) key.

NOTE: Alarm messages are shown in the main window only. The main menus **INFO**, **MANUAL**, **SETUP** or **ALARM** must not be selected.

NOTE: The messages **Ai / Abrt**, **PFC / OFF**, **PFC / Hold** and **FAn** are only displayed in the main window if no alarm signal is pending.

NOTE: Only **one** active error or status message is displayed. The error message **Ai / Abrt** has priority over the status message **FAn**. This in turn has priority over **PFC / OFF** or **PFC / Hold**.



6. Operation of the controller

6.1 Operating concept

The CX eco is operated via 4 keys. If no button is pushed within 60 s, the backlight turns off. To turn the backlight on again, any button can be pushed. Afterwards, the standard key functions are available again. Depending on the respective menu, the keys have different functions.

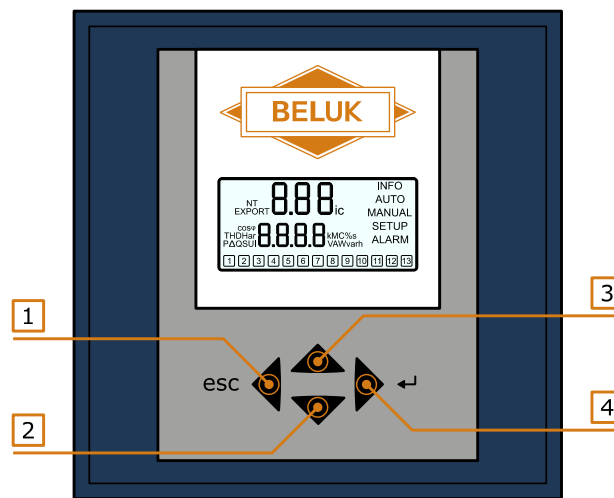

- | | |
|----------|--|
| 1 | <ul style="list-style-type: none"> ▪ Exit menu ▪ Move cursor to the left ▪ Reset alarm (push for 3 s) |
| 2 | <ul style="list-style-type: none"> ▪ Decrease value ▪ Select next value, menu item or stage number |
| 3 | <ul style="list-style-type: none"> ▪ Increase value ▪ Select previous value, menu item or stage number |
| 4 | <ul style="list-style-type: none"> ▪ Open menu ▪ Move cursor to the right ▪ Accept value |



6.2 Entering values

If a menu item has been entered, the first digit of the current value flashes. Numbers can be increased or decreased by pushing the ▲ and ▼ keys.

The next digit can be selected by pushing the ► key. In order to select the previous digit, the ◀ key must be pushed.

If the last digit (right) has been selected and the ► key is pushed again, a multiplier **k** (kilo) or **M** (mega) can be set using the ▲ and ▼ keys. To accept the value and complete the entry, the ► key must be pushed again.

If an entered value has not been accepted and another value is displayed after an input, the entered value has exceeded or fallen below the threshold of the setting range.

An entry can be canceled at any time by pushing the ◀ key. Depending on the actual position, the ◀ key must be repeatedly pushed until the first digit (left) is selected. Pushing the ◀ key again exits the menu item without accepting changes.



7. Menu guide

7.1 Measurement menu

All measured values highlighted in grey are hidden in the factory state and are only displayed if the current transformer factor is set (SETUP/100/Ct).

NOTE: If the device is reset to the factory settings (SETUP/602), the current transformer factor must be entered again in order to display all measured values again.

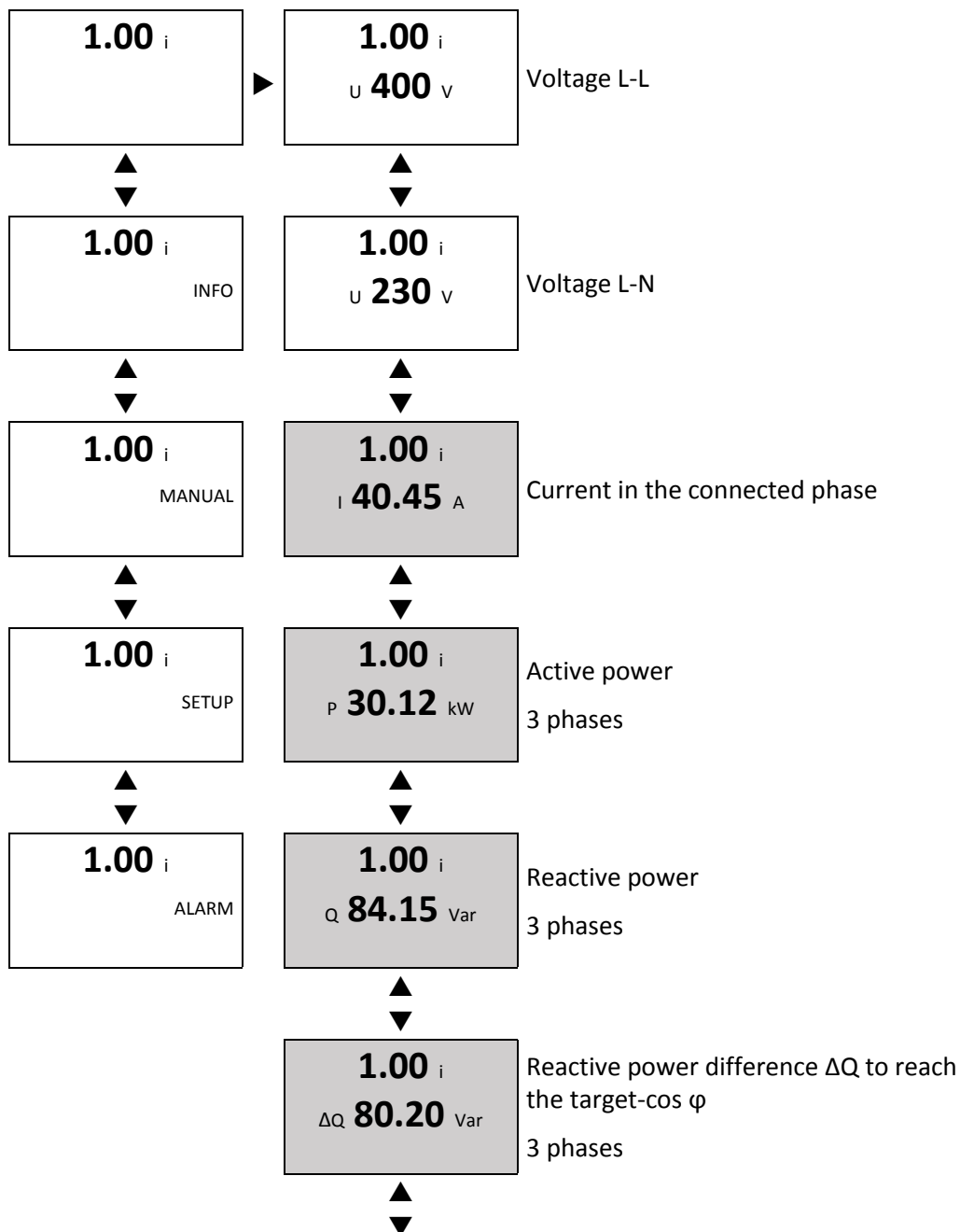

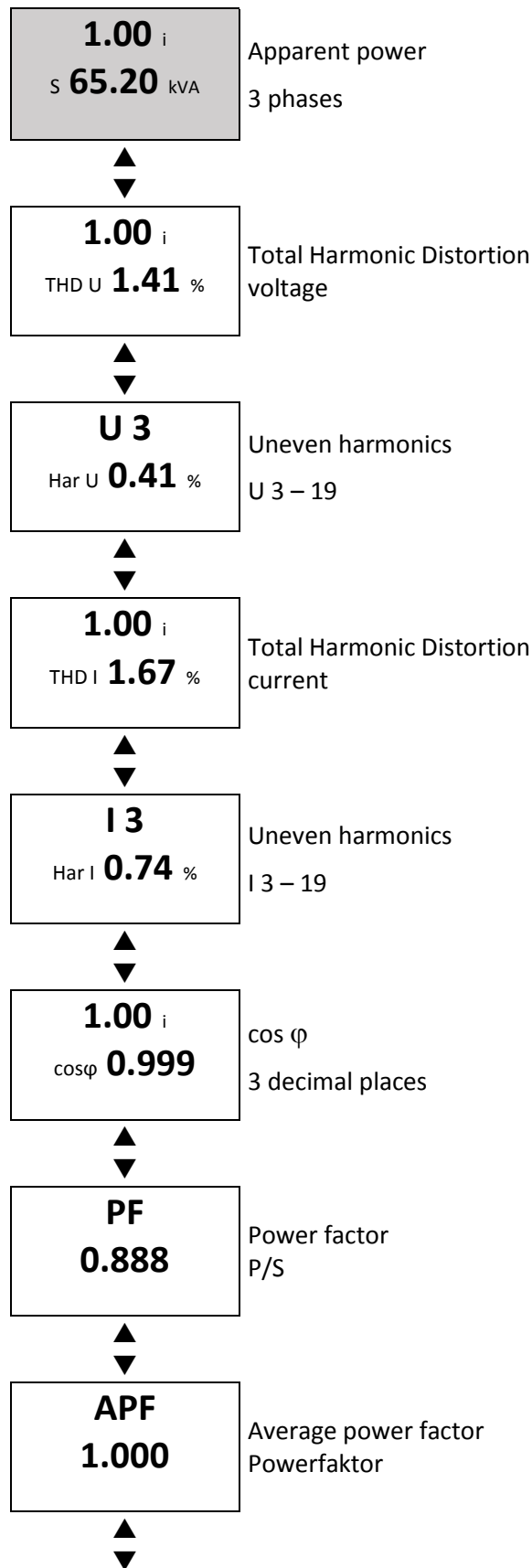

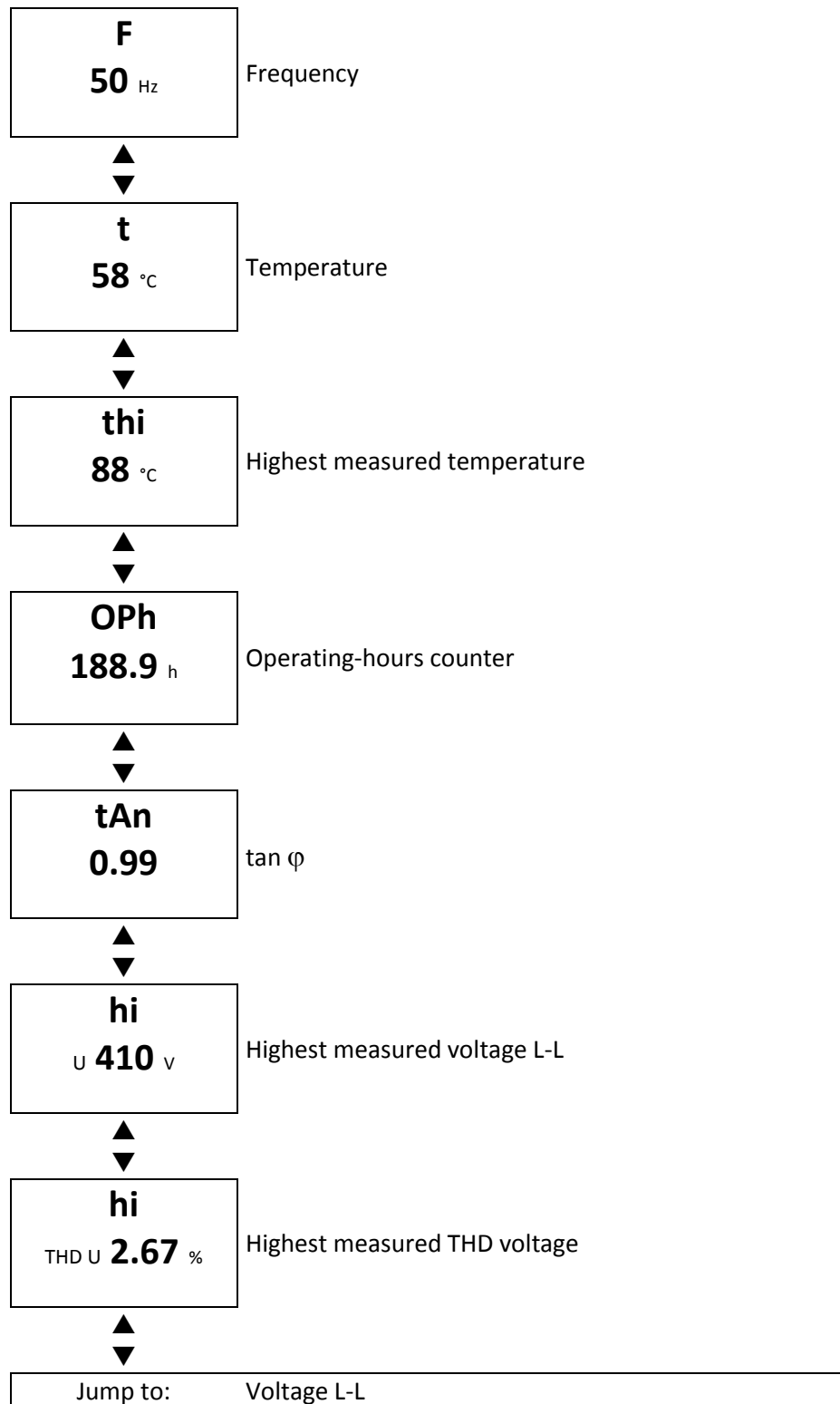



7.2 INFO – Stage database

The INFO menu displays the switching cycles, the operating hours, the stage type and status, the current stage power and the stage power in relation to the initial power (in percent) of each stage. This data can be used to draw conclusions about the status of the system and the status of the single stages.

NOTE: The current stage size is only displayed if the current transformer factor has been entered in the SETUP menu.

The stage power in relation to the initial power (in percent) is only displayed if the stage detection has been completed or the stage size has been entered manually. More information are provided in Chapter 10.

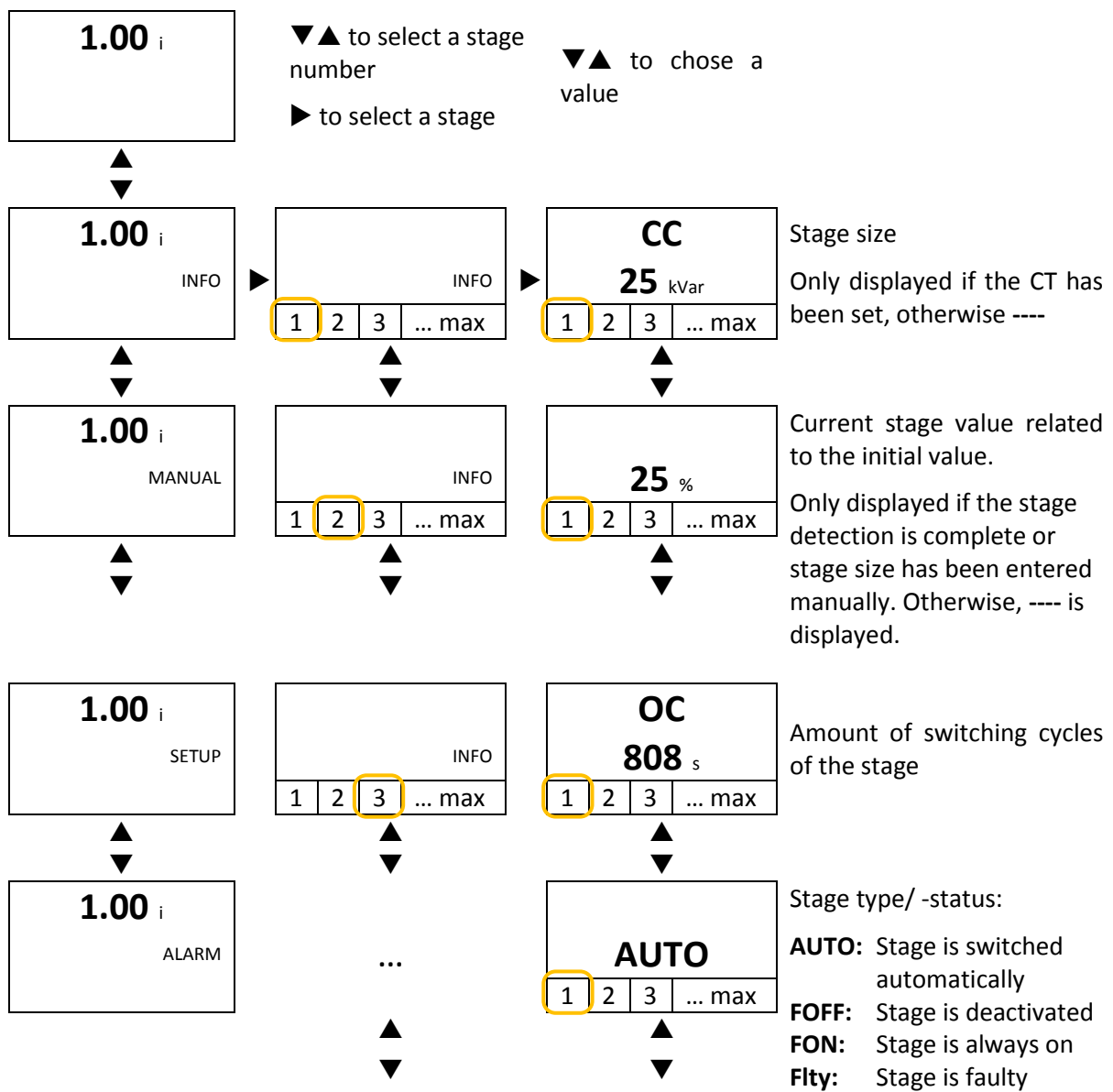

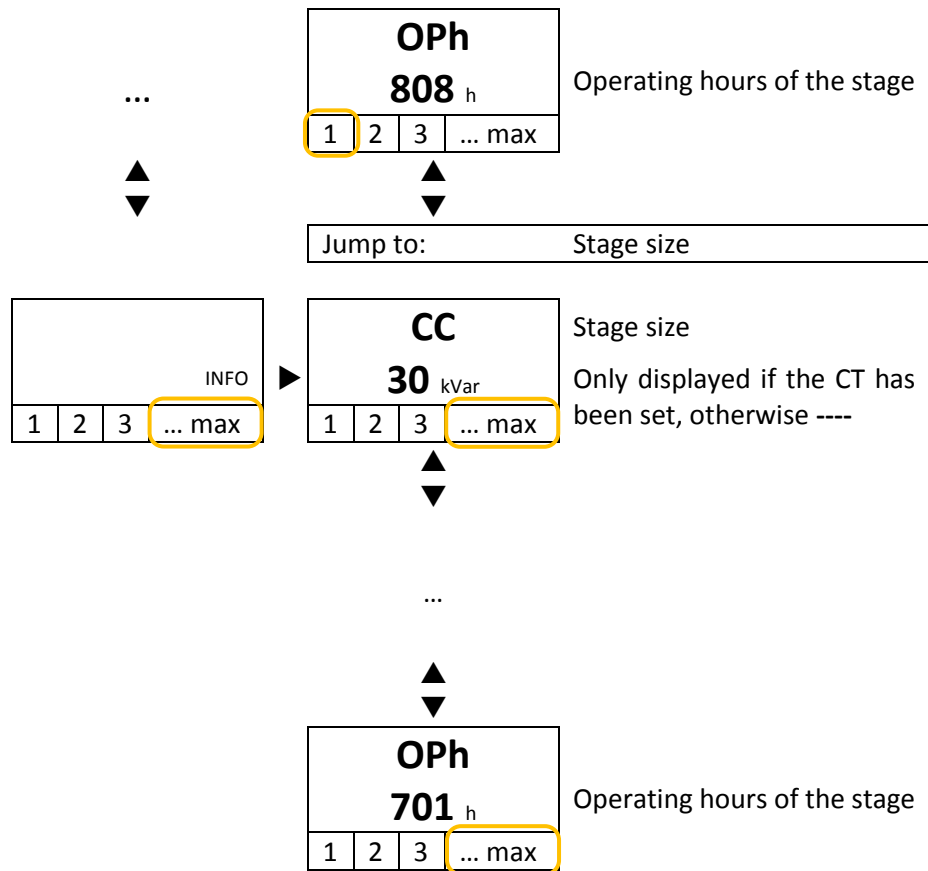

7.3 MANUAL – Switching stage outputs manually

The stage outputs can be switched manually for testing purposes. The automatic control is stopped when the MANUAL menu is entered. Therefore, this menu item is locked to prevent stopping the control unintentionally.

As soon as the menu is left, the control automatically starts and, if necessary, switches off stages that are not required.

In order to access the MANUAL menu, the key ► must be pushed for 3 seconds.

NOTE: The discharge time of the stages is also taken into account when they are switched manually. After a stage has been switched off manually, the discharge time of this stage runs. The affected output can only be switched on again after the time has elapsed.

NOTE: Deactivated stages (**FOFF**), permanently activated stages (**FON**) and blocked stages (**FIt**, **FOFF** due to stage power loss alarm) cannot be switched manually.

NOTE: During the Automatic initialization, switching stages manually is not possible.

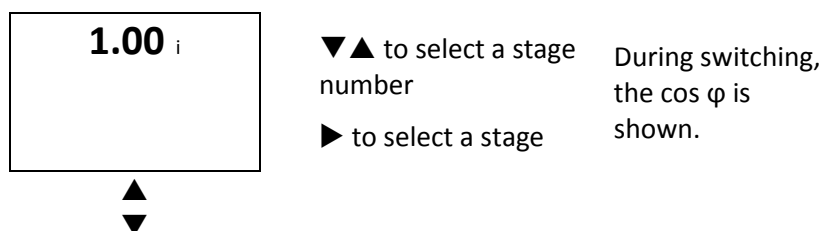

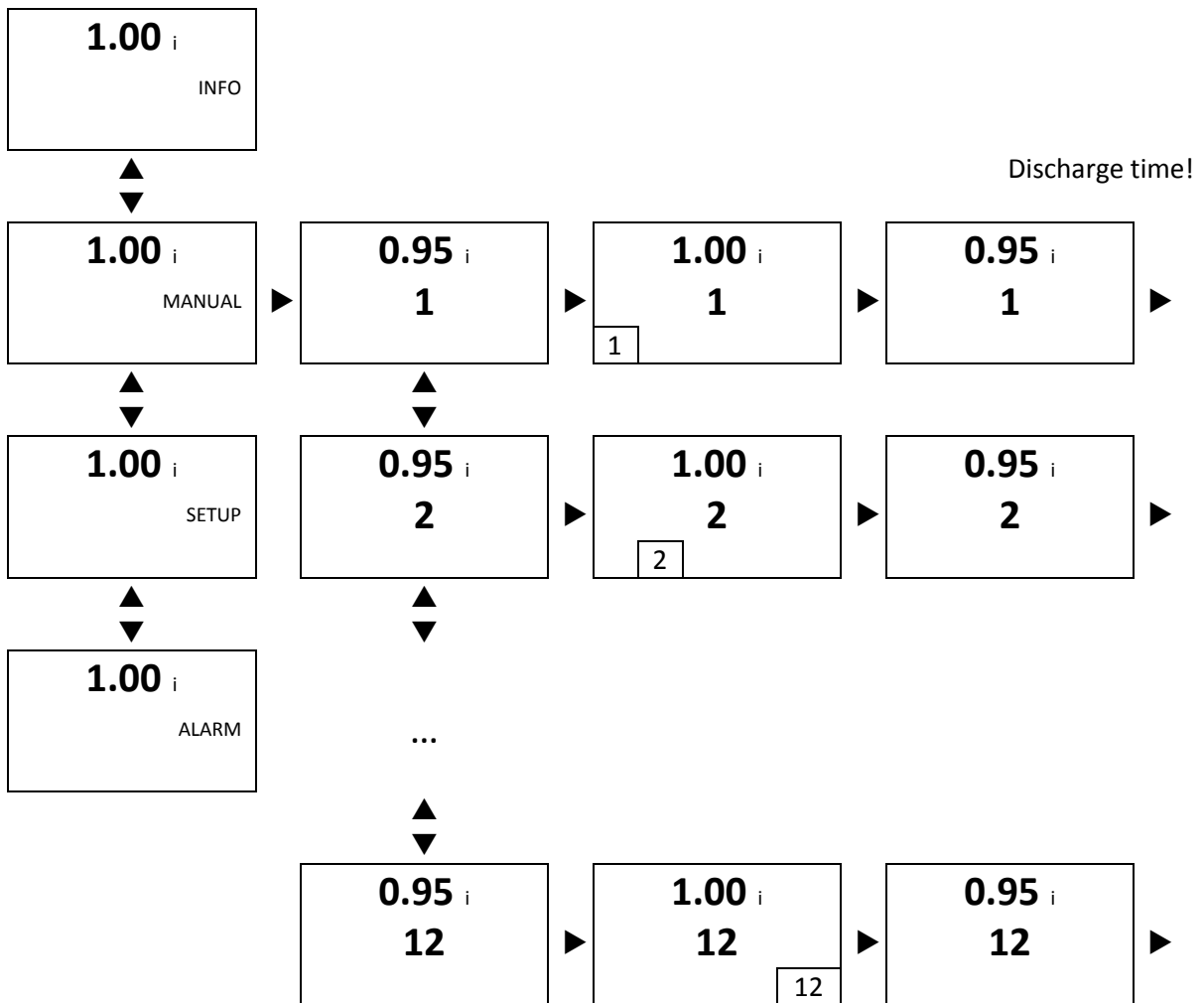

7.4 SETUP – Controller setup

All controller settings can be found in the SETUP menu. A distinction can be made between the Quick Start menu (100) and the restricted Expert menus (200 to 800).

The Quick Start menu contains the most important settings, from the SETUP menus 200 to 400, for commissioning.

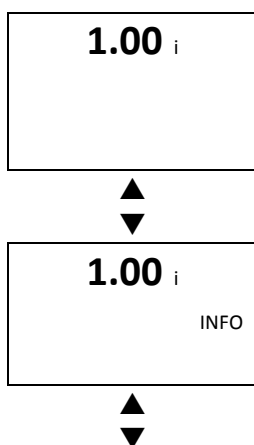

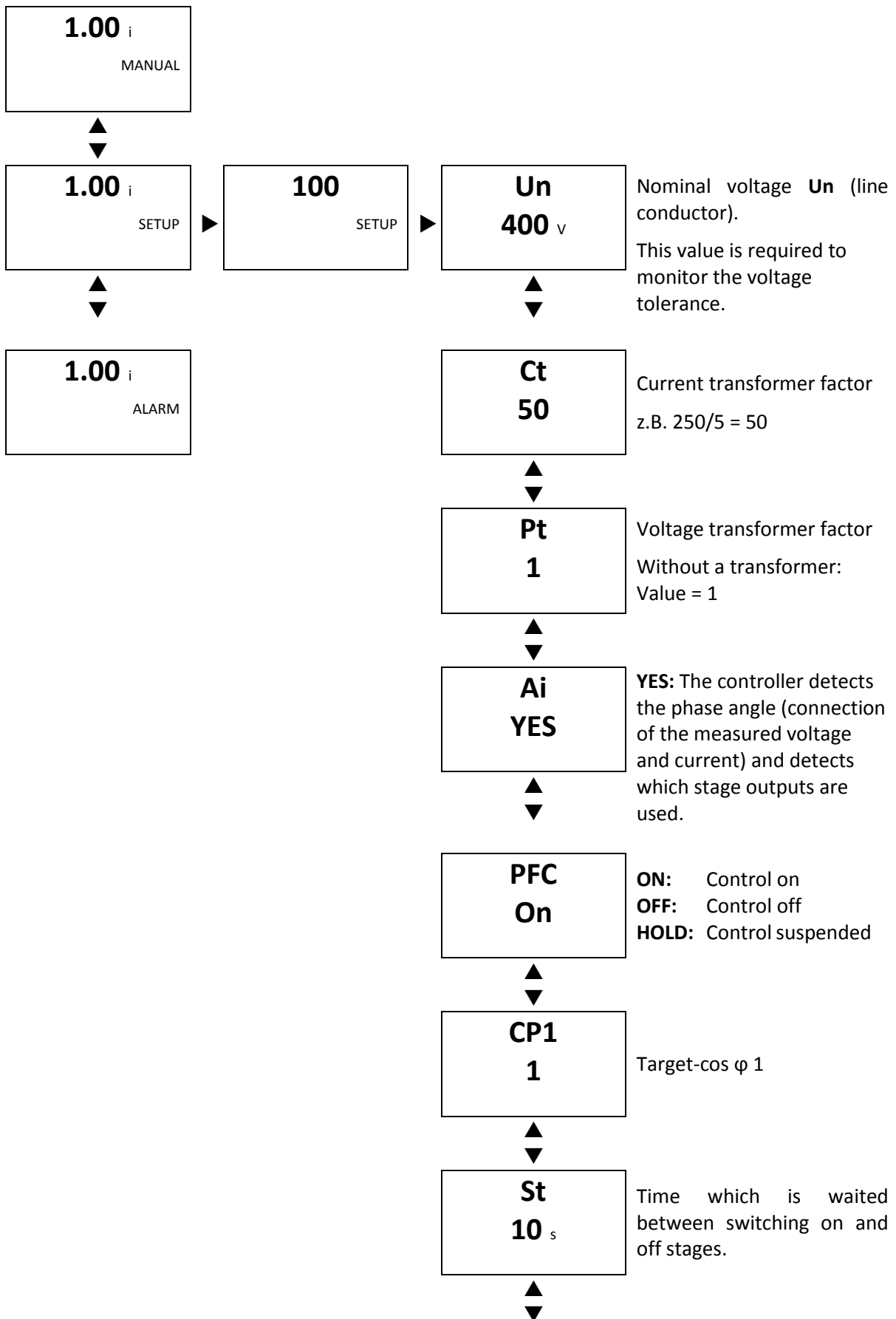



Out

▼▲ to select a stage number

▶ to select a stage

AUTO: Stage is switched automatically

FOFF: Stage is deactivated

FON: Stage is always on

Flty: Stage is faulty (not configurable)

7.5 ALARM – Alarm memory

The alarm memory contains the last 10 alarms. They are arranged in a way that the newest alarm can be found at the memory location 1 and the oldest at the memory location 10.

The alarm memory follows the first in and first out principle. If a new alarm is triggered, it is stored at the memory location 1. As a result, all previous entries (1 – 10) are moved to the next higher position. The alarm which was previously stored at memory location 10 is deleted.

The alarm memory is non-volatile and can be completely reset by simultaneously pushing the ▲ and ▼ keys (approx. 3 s) within the alarm menu. The alarm memory can also be deleted in the reset menu (SETUP/606).

NOTE: All alarms that are not pending will also be reset.

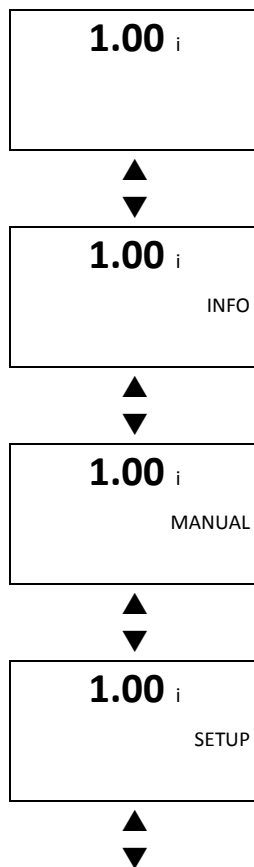

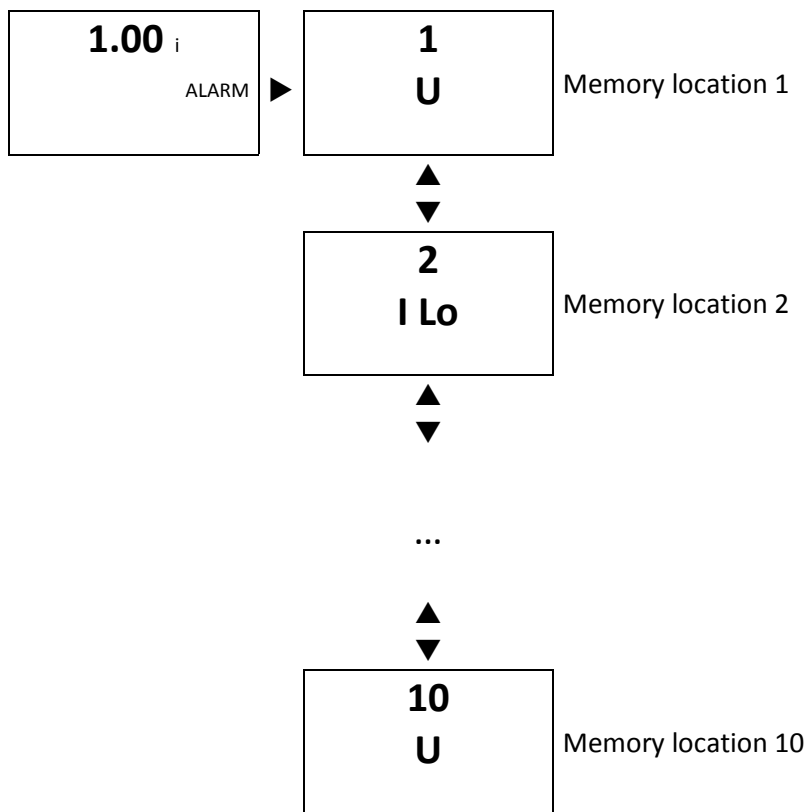



8. Settings

The controller can be configured in the SETUP menu. Here, the Quick Start menu contains all important settings from the menus 200 – 400.

To get from the Quick Start menu to the Expert menus of the CX eco, push the ▼ or ▲ key. Now, a PIN code must be entered.

If the PIN code has been entered and is confirmed by pushing the ► key, the previously hidden menus 200 to 800 can be selected by using the ▼ and ▲ keys.

In order to access the respective submenu, the ► key must be pushed.

NOTE: The PIN code can be changed in SETUP/608. However, the Expert menus can always be entered using the master PIN code **242**. If the PIN code is set to **000**, the Expert menus are no longer protected and all SETUP menus are shown.

8.1 Overview

100 Quick Start

Contains all settings from the setup menus 200 to 400 that are important for commissioning. This menu is always visible.

200 Measurement

Contains settings to adapt the measurement of the CX eco to the power grid conditions.

300 Control

Contains settings to adapt and optimize the control to the system requirements.

400 Stage database

The stage parameters are set in the stage database. If the stage detection is switched off, the stage size must be entered manually for each output.

500 Alarm

In the alarm menu, alarms and monitoring functions can be activated or deactivated and thresholds can be set.

600 Reset menu

Here, values and counters of the controller can be reset. In addition, the software version of the device can be queried and the PIN code for the Expert menus can be set.

700 ---

Menu 700 is not available in the CX eco.

800 System

The duration of the backlighting during the system start can be adjusted in this menu.



8.2 100 Quick Start

Contains the most important settings for commissioning.

100 Quick Start settings

MENU	FUNCTION	RANGE
------	----------	-------

Un	Nominal voltage (line conductor)	100 ... 242000 V
----	----------------------------------	------------------

The correct input of the nominal voltage is necessary, since the upper and lower threshold of the voltage monitoring is determined from this value. The stored stage sizes in the stage database also refer to the set nominal voltage.

Ct	Current transformer factor	1 ... 9600
----	----------------------------	------------

Input of the current transformer factor. The ratio must be entered as factor (e.g. $1000/5 = 200$).

NOTE: If the current transformer factor is entered and

- The automatic stage detection is **deactivated**, the current stage size of all stages is reset to the original value (entered value).
- The automatic stage detection is **activated**, the current and the original stage size of all stages is reset to the starting value of 3 VAr capacitive. The stage detection restarts.

Pt	Voltage transformer factor	1.0 ... 350.0
----	----------------------------	---------------

Input of the voltage transformer factor. The ratio must be entered as factor (e.g. $1000/100 = 10$).

If the device is connected directly to a phase without a transformer, the value **1** must be set.

The voltage transformer factor can be entered with one decimal place. Since only three characters can be displayed, the shown value is rounded up or down.

NOTE: If the voltage transformer factors is entered and

- The automatic stage detection is **deactivated**, the current stage size of all stages is reset to the original value (entered value).
- The automatic stage detection is **activated**, the current and the original stage size of all stages is reset to the starting value of 3 VAr capacitive. The stage detection restarts.

Ai	Automatic initialization	Yes/No
----	--------------------------	--------

YES: Start the Automatic initialization (Ai).

If the Automatic initialization starts, the setting is immediately reset to **NO**. As long as the Ai has not been started (U-alarm, I-Low alarm), the setting remains set to **YES**.

The Automatic initialization successively switches all stage outputs to determine which outputs are used. Additionally, the phase angle (between the measured voltage and current) is determined. An incorrect connection of the current or voltage is detected and corrected by automatically adjusting the phase-correction-angle.



Stage outputs that are set to **FON** or **Fity** are not taken into account during the Automatic initialization.

NOTE: The Automatic initialization works with capacitors only. If the CX eco compensates a reactive power using choke coils, this function leads to errors.

NOTE: The predominance of constant load conditions favors a successful execution of the **Ai**.

PFC	Control	On/Off/Hold
------------	----------------	--------------------

Starting, suspending and stopping the automatic control. The following settings are available:

ON: Control is on and runs.

OFF: Control is off and active stages are successively switched off in a 3-second intervall.

Hold: Control is stopped and active stages remain switched on.

If the control is set to **OFF**, **PFC** and **OFF** appear alternately in the display.

If the control is set to **Hold**, **PFC** and **Hold** appear alternately in the display.

NOTE: The control is **OFF** and the upper setting is blocked if

- a) The current transformer factor has not been entered.
- b) The stage detection is deactivated and the manual input of at least one stage size has not taken place.

CP1	Target-cos φ 1	0.70 c ... 0.70 i
------------	--	--------------------------

This setting defines the target-cos φ 1 which must be reached by the reactive power compensation (control target).

St	Switching time	1 ... 6500 s
-----------	-----------------------	---------------------

When the automatic control is active, the switching time determines the delay between switching two stages.

The setting of the switching time should be taken place under the following aspects.

- a) The switching time protects the contactors from unnecessarily switching operations and thus from excessive wear.
- b) The required reactive power is averaged over the switching time. Rapid fluctuations of the reactive power can be compensated.

OUt	Stage typ (Stage 1 ... max)	AUTO/FON/FOFF/Fity
------------	------------------------------------	---------------------------

With the exception of the stage type **Fity**, the following stage types can be set for each stage:

AUTO: Stage is automatically switched by the control.

FON: Stage is permanently on (stage is nevertheless monitored and switched off in critical situations).

FOFF: Stage is permanently off or deactivated. Unused stages should be set to this stage type to avoid unnecessary switching operations and alarms.



Flyt: Stage was switched three times without success and detected as faulty. The respective stages are no longer used for control. Faulty stages flash in the lower part of the display.

8.3 200 Measurement

Contains settings to adapt the measurement of the CX eco to the power grid conditions.

200 Measurement settings

MENU	FUNCTION	RANGE
201	Nominal voltage (line conductor) The correct input of the nominal voltage is necessary, since the upper and lower threshold of the voltage monitoring is determined from this value. The stored stage sizes in the stage database also refer to the set nominal voltage.	100 ... 242000 V
202	Current transformer factor Input of the current transformer factor. The ratio must be entered as factor (e.g. 1000/5 = 200). NOTE: If the current transformer factor is entered and <ul style="list-style-type: none"> a) The automatic stage detection is deactivated, the current stage size of all stages is reset to the original value (entered value). b) The automatic stage detection is activated, the current and the original stage size of all stages is reset to the starting value of 3 VAr capacitive. The stage detection restarts. 	1 ... 9600
203	Voltage transformer factor Input of the voltage transformer factor. The ratio must be entered as factor (e.g. 1000/100 = 10). If the device is connected directly to a phase without a transformer, the value 1 must be set. The voltage transformer factor can be entered with one decimal place. Since only three characters can be displayed, the shown value is rounded up or down. NOTE: If the voltage transformer factors is entered and <ul style="list-style-type: none"> a) The automatic stage detection is deactivated, the current stage size of all stages is reset to the original value (entered value). b) The automatic stage detection is activated, the current and the original stage size of all stages is reset to the starting value of 3 VAr capacitive. The stage detection restarts. 	1 ... 350
204	Nominal voltage tolerance This setting determines the tolerance range of the nominal voltage. If the measured voltage is out of the set tolerance, an alarm is triggered.	0 ... 100 %



205	Voltage measurement connection	U-LL / U-LN
-----	--------------------------------	-------------

U-LL: Voltage measurement between L-L

U-LN: Voltage measurement between L-N

Based on the set nominal voltage, the controller calculates the voltages of both connection types (L-L and L-N) from the measured voltage. If these are within the set voltage tolerance (factory setting +/- 10 %), the controller automatically determines the connection type. This cannot be changed manually.

If the measured voltage is out of the adjusted tolerance, the voltage measurement connection can be set manually.

206	Phase-correction-angle	0 ... 345°
-----	------------------------	------------

If the connection of the measured voltage and current results in a phase angle unequal to 0° (voltage measurement L-N) or 90° (voltage measurement L-L), the phase-correction-angle must be set accordingly. An incorrect value has a negative effect on the calculation of the power, $\cos \varphi$, power factor and stage sizes. Thus, the control does not work correctly or not at all.

The phase-correction-angle can be detected automatically by executing the Automatic initialization or can be manually entered in **15° steps**.

If the phase-correction-angle has been correctly detected by the Ai, this value should not be changed.

In case the Automatic initialization fails due to unfavorable power grid conditions, the phase-correction-angle can be entered manually or an incorrectly detected phase angle can be adjusted.

For manual determination of the phase-correction-angle, information are provided in Chapter 17.

NOTE: It is recommended to turn off the control during a manual input of the phase-correction-angle (SETUP/100/PFC or SETUP/310).

207	Automatic initialization	Yes/No
-----	--------------------------	--------

YES: Start the Automatic initialization (Ai).

If the Automatic initialization starts, the setting is immediately reset to **NO**. As long as the Ai has not been started (U-alarm, I-Low alarm), the setting remains set to **YES**.

The Automatic initialization successively switches all stage outputs to determine which outputs are used. Additionally, the phase angle (between the measured voltage and current) is determined. An incorrect connection of the current or voltage is detected and corrected by automatically adjusting the phase-correction-angle.

Stage outputs that are set to **FON** or **Fity** are not taken into account during the Automatic initialization.

NOTE: The Automatic initialization works with capacitors only. If the CX eco compensates a reactive power using choke coils, this function leads to errors.

NOTE: The predominance of constant load conditions favors a successful execution of the Ai.



208	Synchronization frequency	Auto/Fix50/Fix60
	<p>In order to achieve the highest measurement accuracy, the sample rate must be synchronized to the power grid frequency. Despite internal filtering, strong voltage commutation drops can lead to a disturbed automatic synchronization. A disturbed synchronization leads to measurement errors. For this reason, the following settings can be made.</p> <p>AUTO: Automatic synchronization to achieve the highest measurement accuracy in power grids without commutation drops</p> <p>50: For a safe operation in 50 Hz power grids with an extremely poor voltage quality.</p> <p>60: For a safe operation in 60 Hz power grids with an extremely poor voltage quality.</p>	

209	Temperature offset	-10 ... 10 °C
	<p>In order to correct component-dependent deviations, the temperature measurement can be adjusted by a temperature offset.</p>	

8.4 300 Control

Contains settings to adapt and optimize the control to the system requirements.

300 Control settings

MENU	FUNCTION	RANGE
301	Control sensitivity	55 ... 100 %
	<p>The control sensitivity determines the threshold for switching the stages on and off (hysteresis). A low value allows a more accurate compensation result, but increases the number of switching operations.</p> <p>The factory setting is 60 %. If the reactive power deviation to the control target is greater than 60 % of the power of a stage, the stage may be switched on or off. Here, 40 % over-compensation after switching on and 40 % under-compensation after switching off are permitted.</p>	
302	Target-cos φ 1	0.70 c ... 0.70 i
	<p>This setting defines the target-cos φ 1 which must be reached by the reactive power compensation (control target).</p>	
303	---	---
	<p>Menu 303 is not available in the CX eco.</p>	
304	---	---
	<p>Menu 304 is not available in the CX eco.</p>	
305	Switching time	1 ... 6500 s
	<p>When the automatic control is active, the switching time determines the delay between switching two stages.</p>	



The setting of the switching time should be taken place under the following aspects.

- a) The switching time protects the contactors from unnecessarily switching operations and thus from excessive wear.
- b) The required reactive power is averaged over the switching time. Rapid fluctuations of the reactive power can be compensated.

306	Switching time stage exchange	1 ... 6500 s
	Delay between switching off an active stage and switching on another stage, which fits more precisely into the determined demand for reactive power. The normal switching time is not maintained during stage exchange.	

307	Stage exchange	Yes/No
	YES: The controller tries to reach its control target by exchanging stages.	
	NO: The function is disabled.	

NOTE: In order to avoid unnecessary switching cycles, this function should be deactivated when stages of equal size are used.

308	Stage detection	Yes/No
	YES: Stage detection is activated. The stage sizes are automatically determined during operation and continuously updated. Faulty stages and the power losses are detected. Manually entered stage sizes are overwritten by automatic tracking the stage sizes. Once the detection process of a stage has been completed (50 switching operations), its original size is defined as the value of the current measured size.	

The stage detection can also be completed prematurely by manually entering the correct size.

NO: Stage detection is deactivated. The stage sizes must be entered manually, but size tracking, defect stage detection and power loss detection are active. By entering the stage size, the value of the original size is set to the value of the current stage size (entered stage size).

A manual input may be necessary:

- a) If there are large load fluctuations and the stage size is incorrectly detected.
- b) If the switchgear has a delay of more than 200 ms.

NOTE: When the stage detection has been completed or the stage size has been entered manually, the stage database (**INFO**) will display the current stage size in relation to the original stage size in percent.

NOTE: Turning off stage detection will turn the control off (**OFF**) and block it. This setting is blocked until the current transformer factor and at least one stage size has been entered manually. Afterwards, the control can be switched on again.

309	Block faulty stages	Yes/No
	YES: After 3 successive switching operations without a power grid reaction, the stages are classified as faulty and blocked for 24 hours. This refers to stages that have already been detected or manually configured.	



Stages detected as faulty flash in the lower part of the display and have the stage type **FIt** (SETUP/100/Out or SETUP/403).

NO: Faulty stages are not blocked and are used by the controller. This results in unnecessary switching operations.

NOTE: Every 24 hours or after a restart of the controller, stages which have been detected as faulty are set to the stage type **AUTO** and are checked again.

NOTE: If the detection of faulty stages is deactivated (SETUP/316 = **NO**), this function is ineffective.

310 Control ON/OFF/Hold

Starting, suspending and stopping the automatic control. The following settings are available:

ON: Control is on and runs.

OFF: Control is off and active stages are successively switched off in a 3-second intervall.

Hold: Control is stopped and active stages remain switched on.

If the control is set to **OFF**, **PFC** and **OFF** appear alternately in the display.

If the control is set to **Hold**, **PFC** and **Hold** appear alternately in the display.

NOTE: The control is **OFF** and the upper setting is blocked if

- a) The current transformer factor has not been entered.
- b) The stage detection is deactivated and the manual input of at least one stage size has not taken place.

311 Control algorithm 1

1 BEST-FIT: The controller operates according to the BEST-FIT principle. Before each switching operation, the controller compares all stage sizes, stored in its stage database, with the determined reactive power requirement and always selects the stage that comes closest to the set control target. If equal-sized stages are connected to the controller, the number of switching operations are automatically distributed among these stages either via the switching cycles or the operating hours (SETUP/315).

312 Reactive power offset (Q-Offset) -9,9 MVar ... 9,9 MVar

An offset that is added to the measured reactive power. This function allows the compensation of a permanently present reactive load which cannot be measured (e.g. inductance of the upstream supply transformer).

NOTE: The reactive power offset also influences the following measured values: current, reactive power, control deviation, apparent power, power factor, $\cos \varphi$ and $\tan \varphi$.

313 --- ---

Menu 313 is not available in the CX eco.



314	Switch off stages if Q is capacitive	Yes/No
	<p>YES: A capacitive $\cos \varphi$ value is not allowed. If a capacitive $\cos \varphi$ is measured, the controller switches off the necessary reactive power without observing the switching time in order to prevent capacitive power grid conditions.</p> <div style="border: 1px solid black; padding: 5px;"> <p>NOTE: Before switching on a capacitive stage, the control algorithm checks whether it would result in a capacitive power grid condition. If this is the case, the capacitor stage is not switched on in order to prevent an unstable control behavior like oscillation. Here, the control sensitivity (SETUP/301) of the control algorithm is not take into account. This can impair the control accuracy.</p> </div> <p>NO: A capacitive $\cos \varphi$ value is allowed.</p> <div style="border: 1px solid black; padding: 5px;"> <p>NOTE: The target-$\cos \varphi$ 1 is internally limited to 0.98 i if the set value is in the range 0.98 i ... 1.0 i ... 0.70 c.</p> </div> <div style="border: 1px solid black; padding: 5px;"> <p>NOTE: When using inductive stages, this option must be set to NO.</p> </div>	
315	Distribute switching operations	Yes/No
	<p>YES: The switching operations of equal-sized stages are distributed over the operating hours of the individual stages.</p> <p>NO: The switching operations of equal-sized stages are distributed via the switching cycles of the individual stages.</p>	
316	Detection of faulty stages	Yes/No
	<p>YES: Faulty stages are detected by the control algorithm.</p> <p>If a stage is detected as faulty, while switching it on, it is immediately switched off again. If the option is activated (SETUP/309 = YES), the respective stage is set to Ffty after 3 consecutive unsuccessful switching operations and is no longer used by the control algorithm.</p> <div style="border: 1px solid black; padding: 5px;"> <p>NOTE: During the first 3 switching cycles, the stage type of the affected output is set to FOFF instead of Ffty. This prevents unused stage outputs from being treated as faulty.</p> </div> <p>NO: Faulty stages are not detected by the control algorithm during switching operations. Activated stages remain active until the deviation from the actual control value to the setpoint allows a switching operation. This makes the option SETUP/309 ineffective.</p>	

8.5 400 Stage database

All stage parameters are set in the stage database.

400 Stage database settings

MENU	FUNCTION	RANGE
401	Discharge time	1 ... 1200 s
	<p>The set discharge time applies to all stages and is a blocking time that runs after a stage has been switched off. The intention is to completely discharge capacitor stages before they are switched on again.</p> <p>As long as the blocking time has not expired, the corresponding stage is not available. The discharge time must be adapted to the connected capacitors.</p>	



402	Nominal stage size (Stage 1 ... max)	-9,9 MVAr ... 9,9 MVAr
	If the automatic stage detection is disabled, the nominal size of each stage must be entered manually. The entered value refers to the set nominal voltage.	
	<p>NOTE: If the stage detection has been completed for a stage or the stage size has been entered manually, its current size will appear in the stage database (INFO) in relation to the original stage size in percent.</p>	
403	Stage type (Stage 1 ... max)	AUTO/FON/ FOFF/Flty
	With the exception of the stage type Flty , the following stage types can be set for each stage.	
	AUTO: Stage is automatically switched by the control.	
	FON: Stage is permanently on (stage is nevertheless monitored and switched off in critical situations).	
	FOFF: Stage is permanently off or deactivated. Unused stages should be set to this stage type to avoid unnecessary switching actions and alarms.	
	Flty: Stage was switched three times without success and detected as faulty. The respective stages are no longer used for control. Faulty stages flash in the lower part of the display.	
404	Stage switching-operations counter (Stage 1 ... max)	0 ... 500000 cycles
	For each complete switching operation (switching on and off) of a stage, the switching-operations counter of the affected stage is increased by 1. The number of switching cycles of a stage may indicate the condition of the capacitor duty contactors.	
	If the service alarm is activated (Setup/506 = YES) and the switching-cycle counter of a stage exceeds the set threshold (Setup/507), the OPC alarm (max. switching cycles) is triggered and displayed.	
	If, for example, the power contactor of a stage has been replaced, the switching-cycle counter of the affected stage can be reset to 0 in this menu. This resets a pending OPC alarm and monitoring restarts.	
	If several equal-sized stages are connected and the switching-cycle distribution is done via the number of switching operations (SETUP/315 = NO), the switching-cycle counters of the affected stages are taken into account. These stages have the same number of switching operations (+/- 1).	
405	Stage operating-hours counter (Stage 1 ... max)	0 ... 65500 h
	While stages are switched on, an operating-hours counter runs for each stage and provides information about the running time and condition of the capacitors.	
	If the service alarm is activated (Setup/506 = YES) and the operating-hours counter of a stage exceeds the set threshold (Setup/509) by 1 hour, the OPh stage alarm (max. operating hours stages) is triggered and displayed.	
	If, for example, a capacitor has been replaced, the operating-hours counter of the affected stage can be reset to 0 hours in this menu. This resets a pending OPh stage alarm and the monitoring restarts.	



NOTE: Operating hours must be entered as whole hours.

If several equal-sized stages are connected and the switching-cycle distribution is done via the operating hours (SETUP/315 = **YES**), the counters of the affected stages are taken into account.

406 Fan relay as stage output Yes/No

YES: The fan relay is used as 7th or 13th stage output. It is controlled by the control.

NO: The fan relay is used normally. It is controlled by the alarm system.

NOTE: If this option is modified, all active stages are switched off successively and the control restarts. **FON** stages are not affected.

8.6 500 Alarm

In the alarm menu, alarms and monitoring functions can be activated and deactivated and thresholds can be set.

NOTE: The following alarm types cannot be disabled: **U alarm**, **I-High alarm**, **THD-U alarm**, **THD-I alarm** and **TEMP2 alarm**

NOTE: The threshold of a **U alarm** is indirectly set by the nominal voltage (SETUP/100/Un or SETUP/201), voltage tolerance (SETUP/204) and voltage transformer factor (SETUP/100/Pt or SETUP/203).

500 Alarm settings

MENU	FUNCTION	RANGE
501	Reset alarms manually	Yes/No
	YES: An alarm messages must be reset manually. To reset an alarm, the ◀ (esc) key must be pushed for approx. 3 s .	
	NOTE: An alarm message can only be reset if the alarm is not pending.	
	NO: If an alarm message is not pending, it is automatically reset after 15 s.	
502	THD-U threshold	3 ... 20 %
	If the set value is exceeded, an alarm is displayed after the set delay time (SETUP/504) has elapsed. The display shows the message HarU and ALARM .	
503	Switch off active stages when THD-U / THD-I / TEMP2 alarm	Yes/No
	YES: If the set THD-U, THD-I or TEMP2 threshold is exceeded, all active stages (AUTO & FON) are successively switched off with the set switch off interval (SETUP/523).	
	NOTE: As long as an alarm is pending, the control is stopped. Stages which are switched off by the alarm system are blocked for 30 minutes.	
	Stages which have been activated manually are not switched off. If a stage is switched off manually, it is only blocked during the discharge time.	



NOTE: In manual mode, the alarm system does not switch off stages. A pending switch-off sequence starts after leaving the MANUAL menu.

NO: In case of an alarm, active stages are not switched off.

504	THD-U, THD-I alarm delay	1 ... 255 s
	Delay until a THD-U or THD-I alarm is displayed.	

505	Stop control if current is equal zero	Yes/No
-----	---------------------------------------	--------

YES: If the current in the CT's secondary circuit is less than 5 mA, the control is stopped. All active stages remain switched on.

NO: If the current in the CT's secondary circuit is less than 5 mA, the I-Low alarm is displayed. The controller switches off all active stages successively using an interval of 60 seconds.

If the measured current is greater than or equal to 5 mA, the control is switched on again and stages are switched again. An active switch-off sequence is aborted in this case.

NOTE: Active **FON** stages and stages which have been manually activated are not switched off.

506	Service alarm	Yes/No
-----	---------------	--------

YES: A service alarm is displayed if one of the following thresholds has been exceeded.

- a) The operating hours of the controller.
- b) The operating hours of at least one stage.
- c) The maximum switching cycles of a stage.

NO: The service alarm is not displayed.

507	Max. switch operations of a stage	1 ... 50000
-----	-----------------------------------	-------------

If the service alarm is activated (SETUP/506 = **YES**) and the threshold of the maximum switching cycles is exceeded by at least one stage, the service alarm is displayed immediately. The display shows **OPC** and **ALARM** alternately with the stage number. Only the smallest stage number of the affected stages is shown.

Before resetting the alarm, it is necessary to replace the affected contactors as part of a maintenance measure. Afterwards, the switching-cycle counters of the affected stages must be set to **0** (SETUP/404).

508	Max. operating hours of the controller	1 ... 65500 h
-----	--	---------------

If the service alarm is activated (SETUP/506 = **YES**) and the threshold of the operating hours is exceeded by 1 hour, the service alarm is displayed immediately. The display shows **OPh** and **ALARM**.

Before resetting the alarm, a maintenance should be carried out. Afterwards, the controller's operating-hours counter must be reset to **0** hours (SETUP/603).

NOTE: Operating hours must be entered as whole hours.



509	Max. operating hours of a stage	1 ... 65500 h
	<p>If the service alarm is activated (SETUP/506 = YES) and the threshold of the operating hours is exceeded by 1 hour, the service alarm is displayed immediately. The display shows OPh ALARM and the affected stage number alternately.</p> <p>Before resetting the alarm, a maintenance should be carried out at the affected stage. Afterwards, the operating-hours counter of the affected stage must be reset to 0 hours (SETUP/405).</p>	
	<p>NOTE: Operating hours must be entered as whole hours.</p>	
510	THD-I threshold	1 ... 100 %
	<p>If the set value is exceeded, an alarm is displayed after the set delay time (SETUP/504) has elapsed. The display shows the message HArl and ALARM.</p>	
511	---	---
	<p>Menu 511 is not available in the CX eco.</p>	
512	TEMP1: Fan temperature threshold	3 °C ... (TEMP2 - 5 K)
	<p>If the temperature threshold TEMP1 is exceeded, the controller switches on the fan. The switched output is indicated by a flashing FAn lettering in the lower line of the main menu. If the temperature falls below TEMP1 by 5 K, the controller switches off the fan output after 10 seconds.</p>	
	<p>NOTE: If the fan output is configured as additional stage output (SETUP/406 = YES), it is not controlled by the alarm system.</p>	
513	TEMP2: Alarm temperature threshold	(TEMP1 + 5 K) ... 60 °C
	<p>If the temperature limit TEMP2 is exceeded, an alarm is displayed after a delay time of 10 s. The display shows thi and ALARM.</p>	
514	Control alarm: target-cos φ cannot be reached	Yes/No
	<p>YES: If the controller cannot reach the target-cos φ after 75 times of the switching time, because there are no suitable stages available, the control alarm is displayed. PFC and ALARM appears in the display.</p> <p>NO: The control alarm is deactivated.</p>	
515	Stage alarm: faulty stages	Yes/No
	<p>YES: If the SETUP/309 function is activated and at least one stage is detected as faulty after 3 consecutive unsuccessful switching operations, the stage alarm is displayed. Step ALARM and Fity are shown alternately. Stages which are detected as faulty are blocked and flash in the lower part of the display.</p> <p>NO: Stage alarm is deactivated.</p>	
516	Stage alarm: stage power loss	Yes/No
	<p>YES: If the current size of at least one stage falls below 75 % of the original value, a stage power loss alarm is displayed.</p> <p>The display shows SPI ALARM alternately with the stage number. Only the smallest stage number of the affected stages is shown.</p>	



The stage type of the affected outputs is set to **FOFF** and cannot be changed. The affected stage cannot be used by the control.

To reset the alarm and activate the affected stages, they must be replaced. Then the sizes of the affected stages must be entered manually (SETUP/402) so that the current size is equal to the original size (100 %). Afterwards, the stage type can be adjusted again.

NO: The stage power loss alarm is deactivated.

517	Signalize alarm by a flashing display	Yes/No
-----	---------------------------------------	--------

YES: The display flashes if an alarm is pending.

NOTE: Only works if the controller's backlight is turned off. If a key is pushed, the backlight is switched on again and the display stops flashing. After 60 seconds without pushing any key, the display flashes again.

NO: The display does not flash if an alarm is pending.

518	---	---
-----	-----	-----

Menu 518 is not available in the CX eco.

519	---	---
-----	-----	-----

Menu 519 is not available in the CX eco.

520	---	---
-----	-----	-----

Menu 520 is not available in the CX eco.

521	---	---
-----	-----	-----

Menu 521 is not available in the CX eco.

522	Delay time I-High alarm	10 s ... 30 s
-----	-------------------------	---------------

Delay time until the I-High alarm is displayed.

523	Switch-off interval THD-U, THD-I, TEMP2 alarm	1 ... 255 s
-----	---	-------------

The set time corresponds to the interval at which the stage outputs are switched off in the event of an alarm if SETUP/503 is enabled for the THD-U, THD-I and TEMP2 alarms.



8.7 600 Reset menu

In this menu settings, stored values and counters can be reset. Additionally, the software version of the device can be queried and the PIN code changed.

600 Reset menu

MENU	FUNCTION	RANGE
601	Reset settings YES: Resets all settings to the factory settings. The control is switched off temporarily and all active stages (AUTO) are switched off successively. FON stages are not switched off. Afterwards, the control must be switched on again (SETUP/100/PFC or SETUP/310 = ON).	Yes/No
NOTE: The settings SETUP/402, 403,404 and 405 are not affected by a reset.		
NOTE: The nominal voltage, current and voltage transformer factor as well as the phase-correction-angle must be re-entered after a reset. Alternatively, the Automatic initialization can be executed to determine the phase-correction-angle.		
602	Reset stage database YES: Resets the stage database to its factory settings. All active stages, including FON stages, are immediately switched off. The stage sizes, the determined power loss as well as the switching-cycles and operating-hours counters of every stage are reset. A pending service alarm (max. switching cycles or operating hours of stages) is also reset.	Yes/No
NOTE: The setting of the stage discharge time (SETUP/401) and the fan relay configuration (SETUP/406) are not affected by a reset.		
NOTE: If the stage detection is off (SETUP/308 = NO), the control is off and locked. The control is locked until the current transformer factor and at least one stage size have been entered manually. Afterwards, the control can be switched on again (SETUP/100/PFC or SETUP/310).		
603	Reset operating-hours counter YES: Resets the operating-hours counter of the controller. After confirmation, the setting automatically returns to NO .	Yes/No
604	Reset average power factor (APF) YES: Resets the average power factor. After confirmation, the setting automatically returns to NO .	Yes/No
605	Reset maximum measured temperature YES: Resets the maximum measured temperature. After confirmation, the setting automatically returns to NO .	Yes/No



606	Reset alarm messages and memory	Yes/No
	YES: Resets all alarm messages and the alarm memory (ALARM menu). After confirmation, the setting automatically returns to NO .	
	NOTE: An alarm message can only be reset if the alarm is not pending.	
607	Show software version	---
	Displays the software version of the device as ticker xx.xx.xx .	
608	Expert password (PIN code)	0 ... 999
	A PIN code can be set for the SETUP menus 200, 300, 400, 500, 600, 700 and 800.	
	NOTE: The Expert menus can always be entered using the master PIN code 242 . If the PIN code is set to 000 , the Expert menus are no longer protected and all SETUP menus are shown.	
609	---	---
	Menu 609 is not available in the CX eco.	

8.8 700 ---

Menu 700 is not available in the CX eco.

8.9 800 System

This menu contains various system settings.

800 System settings

MENU	FUNCTION	RANGE
801	Backlight during Commissioning mode	Yes/No
	YES: Activates the backlight for commissioning mode.	
	NO: Cancels the backlight commissioning mode. The setting automatically returns to NO after the delay time (SETUP/802) has elapsed.	
802	Backlight duration	0.25/0.50/1.00 h
	Defines the duration of the backlight commissioning mode. During commissioning mode, the remaining time is displayed.	



9. Control algorithm

9.1 BEST-FIT (AUTO)

The controller operates according to the BEST-FIT principle. Before each switching operation, the controller compares all stage sizes, stored in its stage database, with the determined reactive power requirement and always selects the stage that comes closest to the set control target. If equal-sized stages are connected to the controller, the number of switching operations are automatically distributed among these stages either via the switching cycles or the operating hours (SETUP/315).

Blocked faulty stages (**Fity**) and stages of the stage type **FON** and **FOFF** are skipped by the control. If a stage is detected as faulty and locked (**Fity**), it is no longer available for the control. Stages which have been switched off by the alarm system and blocked for max. 30 minutes by a switch-off sequence are also skipped.



10. Automatic initialization

10.1 Run Ai

The Automatic initialization determines the phase angle between voltage and current and detects which stage outputs are used.

The Automatic initialization can be activated in the SETUP menu (SETUP/100/Ai or SETUP/207 = **YES**) and starts as soon as the voltage is within the tolerance and the measured current is greater than 5 mA. The display shows **Ai run** and the **number** of the active run.

When executing the Ai, the set switching and discharge time is taken into account. **FON** and **Flty** stages are ignored by the Ai. If stages have been switched on by the control, they are switched off successively before the Ai can start. If the measured power change during a run is too small, in the next run all stages are successively switched on and afterwards they are successively switches off again.

If the Automatic initialization has been successfully within **maximum four runs**, the determined phase-correction-angle is automatically set and unused stage outputs are set to stage type **FOFF**. **AUTO** appears in the display and after the discharge time has elapsed, the control starts switching stages. Here, the set switching time is taken into account.

The duration of the Automatic initialization depends on the number of runs, the number of stage outputs, the set switching time and the discharge time of the stages.

NOTE: The Automatic initialization determines the phase angle between voltage and current and detects which stage outputs are used. However, the automatic detection of the stage sizes is performed during the usual control.

NOTE: The Automatic initialization is only possible in conjunction with capacitive stages. The use of inductive stages requires a manual input of the phase-correction-angle (SETUP/206). Moreover, the stage sizes must be entered manually (SETUP/402).

NOTE: Due to load fluctuations, it may happens that the Ai does not correctly recognize used stage outputs. Therefore, it is necessary to check whether all connected stages have the stage type **AUTO**.

10.2 Abort Ai

The Ai can be aborted manually at any time (SETUP/100/Ai or SETUP/207 = **►**). For this purpose, the subsequent check query must be confirmed with **YES**. The phase-correction-angle and connected stages are not determined. Furthermore, the control is off.

The Ai is automatically aborted if the phase angle is not detected within **four runs**. The display shows **Ai** and **Abrt** alternately and the control is stopped.

If the Ai is not successful after several attempts, the phase-correction-angle must be set manually (SETUP/206). Furthermore, the stage types must be configured manually (SETUP/100/Out or SETUP/403) and the control must be restarted (SETUP/100/PFC or SETUP/310 = **ON**).



11. Stage features

11.1 Automatic stage size detection

If stage detection is activated (SETUP/308 = **YES**), the CX eco determines the size of the stages automatically during each switching operation. After 50 switching operations (switching on 25x, switching off 25x) the stage detection of a single stage is completed. Now, monitoring of the stage power loss is active for this stage.

NOTE: The stage detection can be completed prematurely at any time, and for each stage, by manually entering the stage size.

If the controller cannot detect a power grid reaction during the first 3 switching operations (switch on 3x, switch off 3x), the stage type of the affected stage is set to **FOFF**. It is assumed that no stage is connected to the output.

NOTE: If the current or voltage transformer factor is entered, all stage sizes (current and original stage size) are reset to a starting value of 3 VAr capacitive. The stage detection starts from the beginning.

NOTE: The automatic stage detection is only possible in conjunction with capacitive stages. The use of inductive stages requires a manual input of the stage sizes (SETUP/402).

11.2 Manual stage size adjustment

If the automatic stage detection is off (SETUP/308 = **NO**), the stage sizes (nominal value) must be entered manually (SETUP/402). Otherwise, the controller will switch stages on and immediately off again, since the start value in the stage database (3 VAr capacitive) differs greatly from the actual stage size. After the stage size has been entered, monitoring of the stage power losses is active.

NOTE: The automatic tracking and adjustment of the stage size is also active when the stage detection is switched off.

NOTE: If the current or voltage transformer factor is entered, the current stage size of each stage is manually reset to the last entered value.

NOTE: Turning the stage detection off will set the control off (**OFF**) and block it. This setting is blocked until the current transformer factor and at least one stage size has been entered manually. Afterwards, the control can be switched on again.

11.3 Adding stages

If an existing plant must be extended by one or more stages, these can be simply added to the stage database.

For this purpose, the stage type of the additionally connected stages must be set to **AUTO** (SETUP/100/OUT or SETUP/403).

If stage recognition is switched off (SETUP/308 = **NO**), the stage sizes of these stages must be entered manually (SETUP/402) as well.



11.4 Detect power losses

The CX eco continuously determines the current stage size when a stage is switched.

$$\text{Stage size [\%]} = \frac{Q_{\text{current}}}{Q_{\text{original}}} * 100$$

If the current stage size falls below 75 % of the original size, the alarm system can trigger an alarm and switch off and permanently disable the affected stages. The display will show **SPL ALARM** and the affected stage number alternately. If several stages are affected, only the smallest stage number of the affected stages is displayed.

In order to activate this option, the **Stage alarm: stage power loss** must be activated (SETUP/516 = **YES**). Afterwards, affected stages are always switched off immediately and the stage type is set to **FOFF**. These outputs are blocked for the control and in manual mode. The stage types of the affected stages are blocked and cannot be changed.

The intention of the **Stage alarm: stage power loss** is to protect detuned capacitor stages. Due to the aging of capacitors, the resonance frequency of detuned systems increases. Harmonic currents are therefore less attenuated and can lead to an overloading of the chokes or capacitors.

To reset the alarm and activate the affected stages again, the affected stages must be replaced. Afterwards, the size of each new stage must be entered manually (SETUP/402) and the stage type must be set to **AUTO** (SETUP/403). Subsequently, these stages can be used by the control or in manual mode.

NOTE: Stage monitoring does not become active until the stage detection has been completed or the stage size has been entered manually.

11.5 Detection and reset of faulty stages

Stages whose size has already been adopted are classified as faulty by the control system after 3 successive switching operations without a power grid reaction. If the **Block faulty stages** function is activated (SETUP/309 = **YES**), the stage type of the affected stage is set to **Fity** and it is blocked for 24 hours. Affected stages neither can be switched by the control nor manually. The stage symbol of the faulty stage flashes in the lower part of the display.

After 24 hours, the controller resets the stage type of the affected stage to **AUTO** and tests it again. If no power grid reaction is detected after 3 successive switching cycles, the affected stage is blocked again for 24 hours (stage type = **Fity**) by the controller.

If a faulty stage has been replaced, the stage type can be manually switched back to **AUTO** (SETUP/100/OUT or SETUP/403). Afterwards, the stage is available for control and can also be switched in manual mode. When replacing stages, the new stage size must be manually entered in the stage database (SETUP/402).

If a defective power contactor has been responsible for the alarm, the switching-cycle counter of the affected stage (SETUP/404) must be manually reset to **0** after the contactor has been replaced. Through this, the switching-cycle monitoring of the contactor restarts.



11.6 Automatic switching distribution

The CX eco automatically distributes switching operations between **equal-sized** stages. This distribution is made either via the **number of switching cycles** or via the **operating hours** of the stages.

Distribution of switching operations

If several equal-sized stages are connected and the switching-cycle distribution is done via the number of switching operations (SETUP/315 = **NO**), the switching-cycle counters of the affected stages are taken into account. These stages have the same number of switching operations (+/- 1).

A distribution via the number of switching operations is useful if contactors are used to switch the capacitor stages. The contactors are equally stressed and an excessive wear of single contactors is prevented.

Distribution of operating hours

If several equal-sized stages are connected and the switching-cycle distribution is done via the operating hours (SETUP/315 = **YES**), the counters of the affected stages are taken into account. These stages are switched in a way that the operating hours are distributed equally.

A distribution via the number of operating hours is recommended if an equal aging of the connected capacitors is intended.

11.7 Additional 7th or 13th stage output

The CX eco provides 6 or 12 switching outputs. If a further stage output is required, the fan relay can be used for this purpose.

NOTE: The normal function of the fan relay is no longer available.

In order to use the fan relay as a 7th or 13th stage output, the fan relay output must be configured as additional stage output (SETUP/406 = **YES**). All stage functions are now available for this output.

NOTE: If this option is modified, all active stages are switched off successively and the control restarts. **FON** stages are not affected.

NOTE: The fan relay is not suitable for controlling thyristor switches.

The stage type (SETUP/100/OUt and SETUP/403) must be set for the additional switching output. If the stage detection is switched off (SETUP/308 = **NO**), the stage size must be entered manually.

If the stage type is set to **AUTO**, the controller will use the fan relay as a full-fledged 7th or 13th stage. An active 7th or 13th stage is indicated in the lower part of the display by the stage symbol 7 or 13. If the stage type is set to **FON**, the stage is permanently switched on.

11.8 Over temperature protection

The CX eco provides an integrated temperature sensor which can be used to monitor the stage temperature.

For this purpose, a temperature threshold TEMP2 (SETUP/513) must be set in the alarm system. If the set temperature is exceeded all active stages successively are switched off. Due to the following dependence, the temperature threshold TEMP1 may have to be adjusted (SETUP/512) as well.

$$\text{TEMP2}_{\min} = \text{TEMP1} + 5 \text{ K}$$



The protection switch-off of the stages must be activated in the SETUP menu (SETUP/503 = **YES**). In order to minimize power grid perturbations, the time interval of the switch-off sequence can be configured (SETUP/523).

If the temperature threshold TEMP2 is exceeded, the **thi ALARM** message appears in the display after a delay time (SETUP/504). After the set switch-off interval time, the stage switch-off sequence starts. The stage which has been switched on last is switched off first. All active stages are successively switched off, taking the switch-off interval into account, as long as the temperature alarm is still pending. All stages switched off by the alarm system are blocked for 30 min. If all active stages have been switched off, the control is stopped.

If the temperature in the control cabinet drops 5 K below the threshold TEMP2, an active switch-off sequence is aborted. The control starts again and stages are switched on and off. However, stages which has been switched off by the alarm system remain blocked for the duration of the blocking period and are not available for the control.

11.9 THD-U / THD-I protection

In order to protect capacitor stages, the CX eco can successively switch off all active stages in the event of a high total harmonic distortion (THD) level. This applies for the THD of the voltage (THD-U) as well as for the THD of the current (THD-I).

For this purpose, a THD-U (SETUP/502) and THD-I (SETUP/510) threshold can be configured in the alarm system.

Additionally, the protection switch-off of the stages must be activated (SETUP/503 = **YES**). In order to minimize power grid perturbations, the time interval of the switch-off sequence can be configured (SETUP/523).

In case that the THD-U or THD-I threshold is exceeded, **HArU ALARM** (THD-U alarm) or **HArI ALARM** (THD-I alarm) appears in the display after a delay time (SETUP/504). After the set switch-off interval time, the stage switch-off sequence starts. All active stages are successively switched off, taking the switch-off interval into account, as long as the THD-U or THD-I alarm is pending. All stages switched off by the alarm system are blocked for 30 min. If all active stages have been switched off, the control is stopped.

If the THD-U or THD-I falls below the set threshold, an active switch-off sequence is aborted. The control starts again and stages are switched on and off. However, stages which has been switched off by the alarm system remain blocked for the duration of the blocking period and are not available for the control.

NOTE: In order to achieve accurately measured harmonic current values, the current in the secondary circuit of the CT must be greater than 50 mA.



12. Fan control

If the controller is installed in a control cabinet which comes with a fan, the CX eco can be used to control the fan. Here, the temperature is determined by an integrated temperature sensor.

The fan relay must be controlled by the alarm system. For this purpose, the fan relay must not be used as an additional stage output (SETUP/406 = **NO**).

NOTE: If this option is modified, all active stages are switched off successively and the control restarts. **FON** stages are not affected.

Moreover, a temperature threshold TEMP1 must be set (SETUP/512). Due to the following dependence, the temperature threshold TEMP2 may have to be adjusted (SETUP/513) as well.

$$\text{TEMP1}_{\text{max}} = \text{TEMP2} - 5 \text{ K}$$

Now, the fan relay is switched on when the temperature threshold TEMP1 is exceeded. An active fan is indicated in the display (main menu) in the lower line by a flashing **FAn** lettering. If the temperature in the switch cabinet falls 5 K below the temperature threshold TEMP1, the fan relay is switched off after 10 s.

NOTE: A pending error message **Ai / Abrt** is suppressed by the status message **FAN**. If necessary, the error message **Ai / Abrt** must be reset by pressing the ◀ (ESC) key (3 s).



13. Transformer compensation

13.1 Reactive power offset

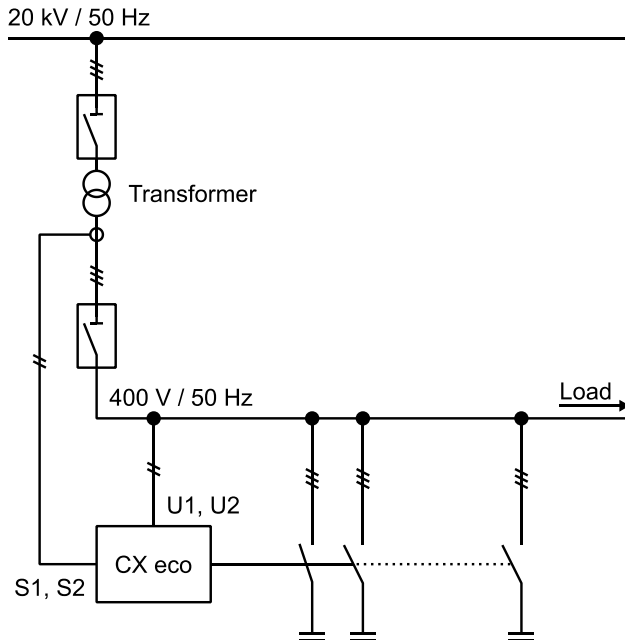

If there are no static stages available to compensate an upstream transformer, this can be done by the control of the CX eco.

For this purpose, the reactive power of the transformer must be made known to the controller as reactive power offset (SETUP/312). The entered value is internally added to the measured reactive power and taken into account in the control deviation.

NOTE: The CX eco always displays the $\cos \varphi$ **before** the transformer. Thus, the $\cos \varphi$ within the low voltage power grid can be capacitive.

13.2 Medium-voltage current measurement

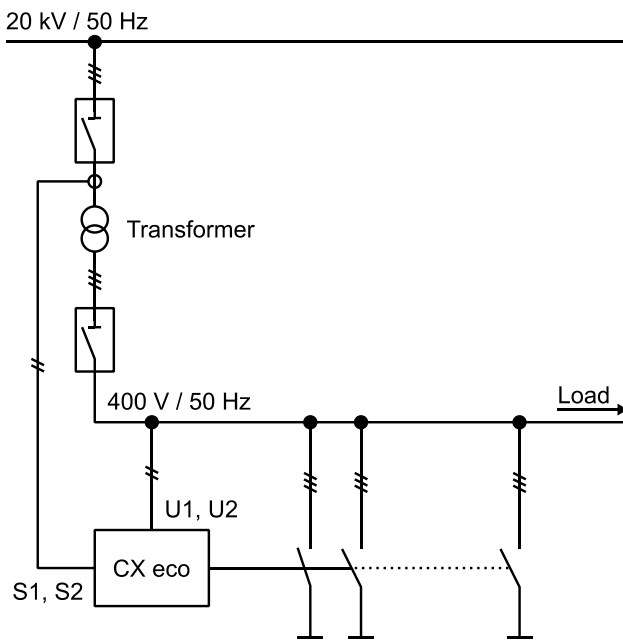

The reactive power caused by the transformer is measured by a medium-voltage current measurement and compensated by the connected compensation system.

In addition to the shown measurement setup, the phase-correction-angle must be taken into account. The phase-correction-angle depends on the wiring of the transformer.

The Automatic initialization can be started to determine the phase-correction-angle (SETUP/100/Ai or SETUP/207 = **YES**).

If the phase-correction-angle is entered manually (SETUP/206), calculation examples are provided in Chapter 17.3.



14. Frequently asked questions

14.1 General

1) Display is off

Possible causes:

Supply or measuring voltage is missing.

Fix:

Check, if the connected measuring voltage is in the range of 90 ... 550 V AC.

Fix:

Check/fix the connection of the measuring voltage.

2) **AUTO** is not shown on the right side

Possible causes:

MANUAL mode is selected or control is suspended or switched off.

Fix:

Start control (SETUP/100/PFC or SETUP/310 = **ON**).

Possible causes:

Current is smaller than 5 mA, voltage or THD-I/U exceeds the valid range, temperature too high, Automatic initialization has been aborted due to an error.

Fix:

Check/adjust the previously listet points.

3) **EXPORT** is shown

Possible causes:

If there is no real reverse current flow, the set phase-correction-angle does not match the connection of the measuring voltage and current.

Fix:

Perform an Automatic initialization (SETUP/100/Ai or SETUP/207) or adjust the phase-correction-angle manually (SETUP/206).

Fix:

Check/adjust the connection polarity. If the connection is twisted by 180°, add or subtract 180° from the manually set phase-correction-angle (SETUP/206). Please refer to Chapter17.2.

4) **Ai Abrt** is shown

Possible causes:

Due to heavy load fluctuations, the Automatic initialization has been aborted.

Fix:

Restart the Automatic initializatin when the power grid has been calmed down.

**Possible causes:**

The measured current is too small. Possibly, the current transformer ratio is too small.

Fix:

Replace the current transformer by a device which fits better to the system. Afterwards, restart the Automatic initialization.

Possible causes:

The stage size is too small.

Fix:

If the Automatic initialization is not successful after several attempts, the correct phase-correction-angle must be set manually (SETUP/206). Stage outputs which are not used can be set manually (SETUP/100/OUT) to the stage type **FOFF**.

The control must be switched on again manually (SETUP/100/PFC or SETUP/310).

5) Wrong $\cos \varphi$ is shown**Possible causes/ Fix:**

See 3).

Possible causes:

The phase-correction-angle is incorrect. The set reactive power offset is not correct.

Fix:

Start the Automatic initialization (SETUP/100/Ai or SETUP/207) or set the phase-correction-angle manually (SETUP/206).

Fix:

Check/adjust the reactive power offset setting (SETUP/312).

6) Current- and power values are not shown

Possible causes:

The current transformer factor is set too small.

Fix:

Check/adjust the current transformer factor (SETUP/100/Ct or SETUP/202).

7) Measured voltage is wrong

Possible causes:

The wrong voltage transformer factor is set or the result of the automatic connection detection is wrong.

Fix:

Check/adjust voltage transformer factor (SETUP/100/Pt or SETUP/203).

Fix:

Check/adjust connection (SETUP/205).

8) Measured current is wrong

Possible causes:

The current transformer factor is wrong.

Fix:

Check/adjust current transformer factor (SETUP/100/Ct or SETUP/202).



14.2 Alarms

1) **U ALARM** is shown

Possible causes:

The entered nominal voltage, voltage transformer factor or voltage tolerance does not fit to the system.

Fix:

Check/adjust nominal voltage (SETUP/100/Un), voltage transformer factor (SETUP/100/Pt) or tolerance range (SETUP/204).

2) **I Lo ALARM** is shown

Possible causes:

Measuring current is smaller than 5 mA. The connection from the current transformer to the controller is not correct. The current transformer bridge has not been removed or the transformer ratio is too high.

Fix:

Check/adjust the connections and the current transformer. The current in the secondary transformer circuit has to be at least 5 mA.

Fix:

Replace the current transformer by a device which fits better to the system.

3) **I hi ALARM** is shown

Possible causes:

Measuring current is higher than 6 A.

Fix:

Replace the current transformer by a device with a higher current transformer ratio.

4) **PFC ALARM** is shown

Possible causes:

Over or under compensation, the set target-cos φ cannot be reached.

Fix:

Check/adjust target-cos φ setting.

Fix:

Check/replace power contactor.

Fix:

Check/adjust stage settings.

Fix:

Check/adjust the dimensioning of the system.

5) **SPL ALARM** is shown

Possible causes:

The current stage size has been fallen below 75 % of the original stage size.

Fix:

Check/adjust stage size. Possibly, it is necessary to replace stages.



14.3 Stages

1) Stages are not switched on

Possible causes:

The available stages are too big.

Fix:

Check/adjust the dimensioning of the system. A finer gradation of the stages sizes may be necessary.

Possible causes:

The discharge times of the stages have not yet expired. A THD-U, THD-I or TEMP2 alarm has blocked the stages for 30 minutes.

Fix:

Wait until the discharge times have been expired.

Fix:

Wait until the block times have been expired.

2) Singel stages are not switched on or off

Possible causes:

The stage type is set to **FON** or **FOFF**.

Fix:

Check/adjust stage type.

3) Stage outputs are immediatly switched off

Possible causes:

The stored nominal stage size of at least one stage fits not to the value in the stage database or no power change has been detecte while switching a stage on.

Fix:

Check/replace stage, fuse or power contactor.

Fix:

If a replacement of stages has been performed, the stage sizes must be manually entered into the stage database.

4) At least one stage is shown as faulty

Possible causes /Fix:

See 3).

5) Outputs are frequently switched

Possible causes:

The stage size in the stage date base still contains the start value (3 VAr).

Fix:

Several switching cycles are necessary to detect the correct stage size of capacitive stages.



6) Power factor does not change if a stage is switched on

Possible causes:

Current transformer is misplaced. Stages are faulty.

Fix:

Check/fix installation position of the current transformer.

Fix:

Check/replace stage or power contactor.

7) Power factor is wrong if a stage is switched on

Possible causes:

Connection of the measuring voltage or current is twisted by 180°. The phase-correction-angle is wrong.

Fix:

Check/adjust the current or voltage connection.

Fix:

Perform an Automatic initialization (SETUP/100/Ai or SETUP/207). If the phase-correction-angle has been entered manually, add or subtract 180° from the manually set angle (SETUP/206). Please refer to Chapter 17.

8) Stages cannot be manually switched

Possible causes:

The discharge times of the stages have not yet expired. A THD-U, THD-I or TEMP2 alarm has blocked the stages for 30 minutes.

Fix:

Wait until the discharge times have been expired.

Fix:

Wait until the block times have been expired.

14.4 Fan

1) Fan does not switch on

Possible causes:

The temperature threshold TEMP1 is set too high. The fan output is used as stage output.

Fix:

Check/adjust the temperature threshold (SETUP/512).

Fix:

Set the fan relay as fan output (SETUP/406 = **NO**)



15. Factory settings

The following table contains all factory settings of the controller. Fields which are highlighted in gray cannot be changed (status displays) or are automatically reset from **YES** to **NO** when **YES** is confirmed (Reset menu).

NOTE: The most important settings for commissioning, from the SETUP menus 200, 300 and 400, are summarised in the Quick Start menu 100. These settings must be adjusted at one point only.

Menu	Factory setting	Customer setting
100		
Un	400 V	
Ct	1	
Pt	1	
Ai	NO	
PFC	ON	
CP1	1	
St	10 s	
OUT	AUTO (Stage 1 ... max)	
200		
201	400 V	
202	1	
203	1	
204	10 %	
205	U-LN/U-LL (Automatically detected)	
206	Voltage measurement L-N = 0° L-L = 90°	
207	NO	
208	AUTO	
209	0 °C	
300		
301	60 %	
302	1	
303	---	
304	---	
305	10 s	
306	2 s	
307	YES	
308	YES	
309	YES	



310	ON	
311	1	
312	0	
313	---	
314	NO	
315	NO	
316	YES	

400		
401	75 s	
402	3 VAr c (Stage 1 ... max.)	
403	AUTO (Stage 1 ... max.)	
404	0 (Stage 1 ... max.)	
405	0 h (Stage 1 ... max.)	
406	NO	

500		
501	NO	
502	20 %	
503	NO	
504	60 s	
505	NO	
506	NO	
507	500 k	
508	65.5 kh	
509	65.5 kh	
510	50 %	
511	---	
512	30 °C	
513	55 °C	
514	NO	
515	NO	
516	NO	
517	NO	
518	---	
519	---	
520	---	
521	---	
522	10 s	
523	60 s	



600		
601	NO	
602	NO	
603	NO	
604	NO	
605	NO	
606	NO	
607	xx.xx.xx	
608	242	
609	---	

700	---	
------------	-----	--

800		
801	NO	
802	0.25 h	



16. Specifications

Voltage measurement / supply

Connection: Single phase
 Range: 90 – 550 V AC, 45 – 65 Hz
 Protection: Max. 6 A
 Power consumption: 6 VA
 Transformer factor: Adjustable 1.0 ... 350.0

Current measurement

Connection: Single phase
 Range: 5 mA – 5 A
 Transformer factor: Adjustable 1 ... 9600

Stage outputs

6 or 12 Stage outputs
 Type: Relay, normally-open, potential-free
 Supply: Common, max. 10 A
 Switching capacity per relay: 250 V AC / 5 A
 400 V AC / 1 A
 48 V DC / 1 A
 110 V DC / 0.2 A

Temperature measurement

Type: NTC under the housing cover
 Accuracy: +- 5 °C

Fan output

Type: Relay, normally-open, potential-free
 Switching capacity: 250 V AC / 5 A
 400 V AC / 1 A
 48 V DC / 1 A
 110 V DC / 0.2 A

Service Interface

For service purpose only

Ambient temperature

Operating: -20 °C – 70 °C
 Storing: -40 °C – 85 °C

Humidity

Range: 0 % – 95 %
 Condensation: Not allowed

Overvoltage category

300 V_{LN} / 519 V_{LL} → CAT III
 519 V – 550 V → CAT II
 Degree of contamination → 2



Standards

IEC 61010-1, IEC 61000 6-2, IEC 61000 6-4: Level B, IEC 61326-1,
UL 61010

Compliance and Listing

CE, c NRTL us (c UL us), EAC

Connections

Type: Screw terminals, pluggable
Cross section: Max. 4 mm²

Housing

Front: Plastic housing (UL94 V-0)
Back: Metal cover

Protection class

Front: IP41
Back: IP20

Weight

Approx. 0,6 kg

Dimensions

Device: H x B x T: 144 x 144 x 58 mm
Cut-out: H x B: 138 (+0,5) x 138 (+0,5) mm



17. Appendix

17.1 Phase-correction-angle: Connection dependent

Depending on the measuring voltage and current connection, a certain phase angle results. For a correct measurement, this must be compensated by entering the respective phase-correction-angle (SETUP/206).

Voltage	L1-N	L2-N	L3-N	L1-N	L2-N	L3-N	L1-N	L2-N	L3-N
Current (CT)	L1	L2	L3	L2	L3	L1	L3	L1	L2
Correction angle	0°	0°	0°	240°	240°	240°	120°	120°	120°

Voltage	L2-L3	L3-L1	L1-L2	L2-L3	L3-L1	L1-L2	L2-L3	L3-L1	L1-L2
Current (CT)	L1	L2	L3	L2	L3	L1	L3	L1	L2
Correction angle	90°	90°	90°	330°	330°	330°	210°	210°	210°

17.2 Phase-correction-angle: Twisted connection

If the current measurement connection is twisted, an additional phase-correction-angle of 180° must be taken into account (SETUP/206). The same applies to a twisted connection of the measuring voltage.

NOTE: If the addition of an **angle x** results in a **phase angle equal to or greater than 360°**, this **angle x** must be subtracted instead.

Example:

Previously set phase-correction-angle = 270°

$$270^\circ + 180^\circ = 450^\circ (\geq 360^\circ!)$$

Actually, the phase-correction-angle must be set to: $270^\circ - 180^\circ = 90^\circ$

17.3 Phase-correction-angle: Medium-voltage current measurement

If the current transformer is positioned in front of the transformer, the phase-correction-angle (SETUP/206) is calculated by taking the winding configuration into account. The following examples illustrate the mathematical approach.

- 1) Winding configuration: Dz6, Voltage measurement U: L3-N, Current measurement I: L1

Phase shift due to the winding configuration Dz6:

$$6 * 30^\circ = 180^\circ$$

Phase offset according to the connection table **U: L3-N, I: L1**:

$$240^\circ$$

Resulting phase-correction-angle:

$$180^\circ + 240^\circ = 420^\circ (\geq 360^\circ!)$$

$$420^\circ - 180^\circ = 60^\circ$$



- 2) Winding configuration: Yd5, Voltage measurement U: L3-L1, Current measurement I: L2

Phase shift due to the winding configuration Yd5:

$$5 * 30^\circ = 150^\circ$$

Phase offset according to the connection table **U: L3-L1, I: L2**:

$$90^\circ$$

Resulting phase-correction-angle:

$$90^\circ + 150^\circ = \mathbf{240^\circ} (\leq 360!)$$

- 3) Winding configuration: Yy6, Voltage measurement U: L1-L2, Current measurement I: L2

Phase shift due to the winding configuration Yy6:

$$6 * 30^\circ = 180^\circ$$

Phase offset according to the connection table **U: L1-L2, I: L2**:

$$210^\circ$$

Resulting phase-correction-angle:

$$210^\circ + 180^\circ = 390^\circ (\geq 360!)$$

$$210^\circ - 180^\circ = \mathbf{30^\circ}$$

- 4) Winding configuration: Yz5, Voltage measurement U: L1-N, Current measurement I: L3

Phase shift due to the winding configuration Yz5:

$$5 * 30^\circ = 150^\circ$$

Phase offset according to the connection table **U: L1-N, I: L3**:

$$120^\circ$$

Resulting phase-correction-angle:

$$120^\circ + 150^\circ = \mathbf{270^\circ} (\leq 360!)$$

NOTE: If the addition of an **angle x** results in a **phase angle equal to or greater than 360°**, this **angle x** must be subtracted instead.

Example:

Previously set phase-correction-angle = 270°

$$270^\circ + 180^\circ = 450^\circ (\geq \mathbf{360^\circ!})$$

Actually, the phase-correction-angle must be set to: $270^\circ - 180^\circ = \mathbf{90^\circ}$